

Duncan

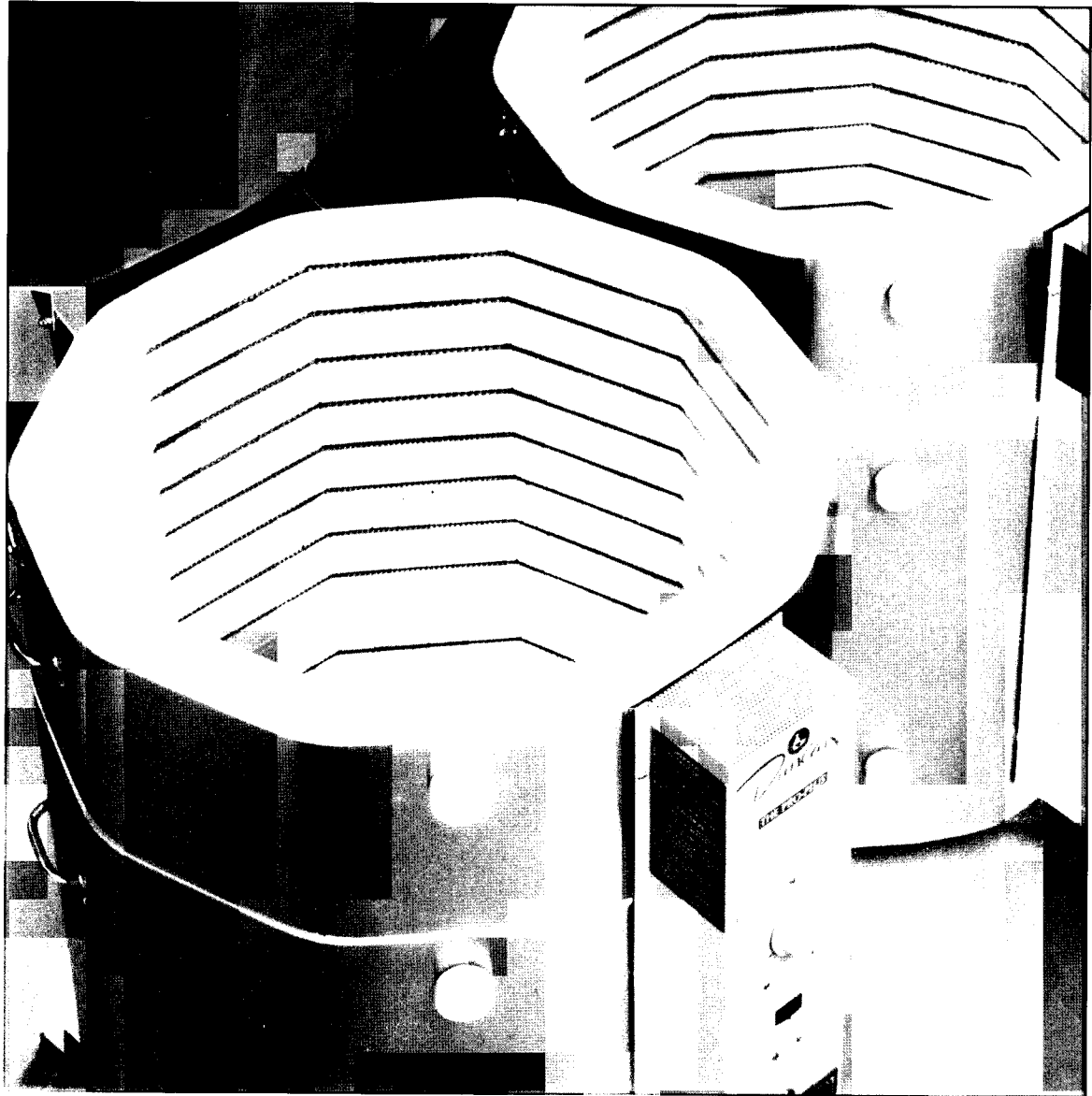

**KILN OWNER'S
MANUAL**

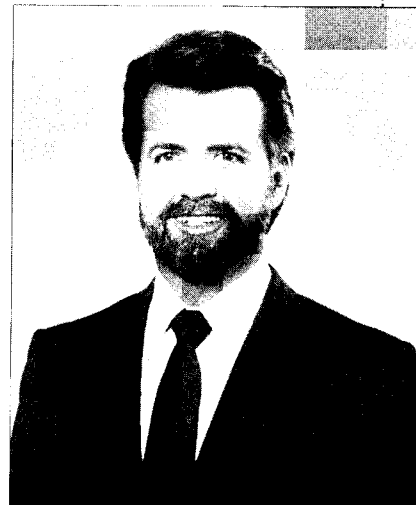

Letter from the President



Thank you for selecting a Duncan Kiln for your ceramics needs.

At Duncan, a great deal of pride and a total commitment to producing only the very best go into every item we make.

Every effort has been taken to ensure that you will have years of trouble-free enjoyment from what I honestly believe is the finest kiln available.

To ensure your fullest enjoyment of your kiln, please take a few minutes to read this manual. It tells you all you need to know about the proper operation of your kiln.

Whether you're using your kiln for personal use or firing the creative work of others, knowing the proper way to use your kiln will give your ceramic pieces the look of quality.

Have fun, enjoy your kiln, and welcome to the Duncan Family!

A handwritten signature in black ink that reads "Larry R. Duncan". The signature is written in a fluid, cursive style.

Larry R. Duncan

PRESIDENT

Directions for Unpacking

1

You should always inspect a new kiln when it arrives. Vibration and jarring in shipping sometimes cause parts of the kiln to become dislodged.

Electrical Needs

2

Your kiln will operate properly only if it is plugged into an outlet that has the correct electrical capacity and voltage to handle it. Because an incorrect connection can be hazardous, always consult a qualified electrician to determine whether the kiln can be wired into the existing electrical supply. The installation of your kiln will be as good as the electrician you use.

The Duncan kiln with model numbers ending in -2 or N are designed to operate on a 240-volt supply, while the -4 models are for 208-volt supplies.

The places where 208-volt power supplies are most likely to occur are schools, hospitals and new shopping centers where there is heavy usage of light fixtures and other 120-volt loads.

Whether you use an existing circuit or have a new one installed, you should have a qualified electrician's help. A kiln will operate properly only if the circuit you use is correctly connected. If you plan to use an existing circuit, be sure that it is large enough and is not used for other purposes while the kiln is firing.

If provided, the plug and cord attached to the kiln must not be changed or altered in any way; this will void the Duncan warranty, as will improper electrical installation (see **Duncan Kiln Specifications**, page 60).

If your kiln stops heating during a firing, be sure to check your fuses or circuit breakers first. Be sure you know what fuses or switches control your kiln and how to replace them.

If you have a hot plug or outlet, one or both may be defective and should be replaced if they are too hot to hold. Do not refire until fixed.

Low-Voltage Supply

If a new kiln is taking excessively long to fire and all its components are working correctly, the voltage the kiln is receiving may not be sufficient. The two most usual causes are: 1) that the transformer serving the building is not supplying enough voltage, or 2) the kiln is firing at a peak period when there is excessive drain on the electric power in the area.

If you suspect low voltage, contact your power company and request that a voltmeter be placed on your line. Usually, there is no charge for this service. The meter will make a continual record of the voltage coming into the building; usually the recording will cover several days. If the voltage is found to be below standard (in most states, this is 240 volts plus or minus 5%), the power company may install a booster or new transformer. If the voltage drops only during peak periods, you should, if possible, arrange to fire at a different time of day.

Three-Phase Supply

An electrician can install a single-phase Duncan kiln on a three-phase circuit by using only two hot legs from the circuit when connecting the kiln's wall receptacle. If more than one kiln is being wired to a three-phase supply, they should be connected to different hot legs to balance the load.

It is important that you determine what your voltage is before hooking up your kiln. If in doubt, contact your local power company for the information. A word of caution! Since some major appliances operate equally well on either 208- or 240-volt supplies, many electricians when asked "Do I have 240 volts?" will say, "Yes," thinking it won't matter. It is much safer to phrase the question, "Do I have 240 or 208 voltage?"

If you have a different voltage than what your kiln requires, it will not operate properly. A 240-volt kiln will low-fire on a 208-volt supply; however, it will take an excessively long time to fire. A 208-volt kiln should never be used on a 240-volt supply as it would draw too much current, causing premature failure of the elements, switches, cord, etc.

Setting Up

Because an improperly installed kiln can be dangerous, we strongly suggest a qualified electrician install or check your house or studio wiring, including the wall receptacle. Never remove even the faceplate from a wall receptacle unless you are a qualified electrician.

Duncan kilns require only a few steps to maintain their safety. After every kiln repair, check the kiln for electrical soundness; and for certain repairs, test-fire the kiln to be absolutely certain it's operating properly.

Before performing any kiln repair, be sure the kiln is unplugged or the power supply has been disconnected.

For Model DB 609, the stand is easy to assemble. Your kiln stand has been designed for maximum support. Operate the kiln *only* on this stand.

1. Follow Figure 1 to assemble the stand legs. The legs go inside the stand frame. The screw holes will not line up unless you follow the illustration.
2. Insert the mar-proof plastic tips on the stand legs.
3. Position the stand on a concrete floor or a high temperature protective sheet, making sure it is level. The stand must be level to alleviate stress on the kiln during firing and to prevent your glazed pieces from falling off the stilts.
4. To level, place a shim UNDER the appropriate leg or legs, not between kiln's bottom and the stand.
5. Center the kiln's bottom on the stand providing for a minimum of twelve inches of clearance between the kiln and the closest wall.
6. Make sure the kiln is sturdy on the stand.

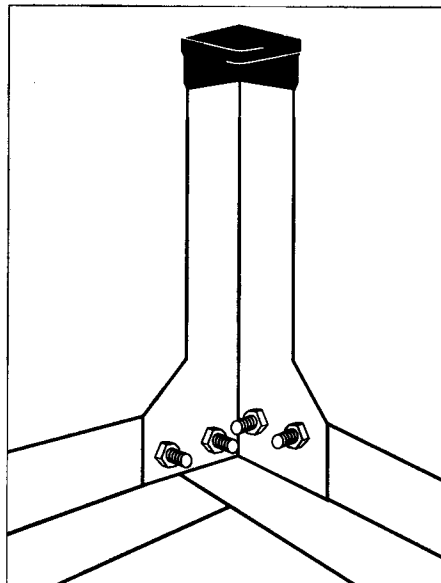

Figure 1

4

Cautions

Safety

Duncan has taken all possible precautions—careful design, high quality-control standards and extensive electrical testing (both by the factory and by independent firms)—to produce a safe kiln.

Duncan kilns have been certified by both Underwriters Laboratory (UL), the recognized United States authority on product safety, and by the Canadian Standards Association (CSA), the Canadian authority. Although the tests and procedures of both organizations are similar, a manufacturer wishing UL and CSA certification must submit the product to each organization.



These certifications are important since they mean recognized electrical parts are used which comply with all applicable UL or CSA safety standards, as well as with the provisions of the National Electrical Code and other nationally recognized installation and use codes.

Underwriters Laboratory Inc., an independent nonprofit corporation and nationally recognized authority on product safety, performs testing for firms who wish to identify their products as complying with UL standards.

Once a kiln or any product has a UL listing, no changes may be made in design or components until they have been approved and, if necessary, tested by UL. Unannounced factory inspections by UL inspectors assure the consumer that UL's registered name or mark is applied only to authorized products and that no unapproved changes have been incorporated. The frequency of these inspections will vary, depending on the product, firm, etc., from several times a week to a minimum of four visits per year.

For safe operation, be sure to follow these tips.

- A kiln should be placed on a level area where it can be easily loaded and operated, and kept out of the way of children and unrelated activities.
- The floor beneath the kiln should be of a material that cannot be discolored by heat and which will not present a fire hazard. Recommended floor surfaces are cement, ceramic tile, brick, stone and the like.
- A kiln should never be placed in a tightly enclosed area, such as a closet or cabinet, as air circulation is needed to prevent overheating.
- A kiln should never be placed in an area that restricts access to the peepholes or control panel.
- When operating the kiln, do not allow the cord to touch the kiln case.
- Never allow shredded paper or other flammable materials to accumulate in the same room with your kiln.
- Remove firing gauge before firing. Adjust ASD prior to your first firing (see **Automatic Shut-off Device**, page 5).
- Extremely hot gases are vented through the lid vent hole. Do not place flammable materials above the kiln. If a lid vent plug is used, exercise caution and wear protective gloves when inserting the plug.
- When the kiln is not in operation, keep switches in OFF position.

Automatic Shut-Off Device (ASD)

The ASD is a mechanical control that's turned on by hand and turned off by the action of the bar or small cone bending under the ASD rod. When the ASD turns off, the kiln will no longer heat. The main benefit of an ASD is the convenience of not having to watch the cones; moreover, the device produces consistent firing time after time.

WARNING: Although an automatic shut-off device turns off the kiln, it can't be considered an absolute guarantee against overfiring. This is why Duncan kilns are equipped with a safety timer. *There is no warranty, express or implied, that covers damage due to overfiring.* A properly set and maintained ASD will certainly make the chance of an overfiring remote; nevertheless, *you are wholly responsible for proper operation.*

ASD Adjustment

Your ASD (see Figure 2) was in adjustment when it was shipped from the factory, but there is a possibility that it may have been jarred during shipment or delivery. Therefore, the following steps must be taken and all necessary adjustments made before the first firing.

1. Turn off all switches.
2. Install firing gauge.

The firing gauge (see Figure 3) was held in place by a rubber band when your kiln left our factory. If the gauge has been removed, it should be positioned over the sensing rod and cone supports.

3. Check position of claw.

With firing gauge in position, raise the weight up against the guide plate. Pull the swivel assembly and check for a $\frac{1}{16}$ -inch clearance between the inside of the claw and the trigger, as shown in Figure 4. The setscrew on top of the claw may be loosened if adjustment of claw position is necessary. Retighten setscrew firmly.

4. Check position of trigger.

With the firing gauge in position, raise the weight up against the guide plate, then slowly swing it forward. The trigger should just clear the tip of the claw, as shown in Figure 5.

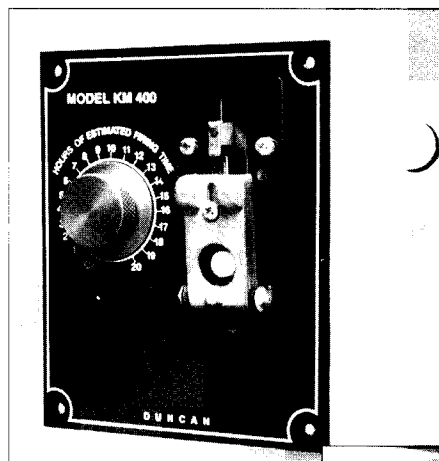

Figure 2

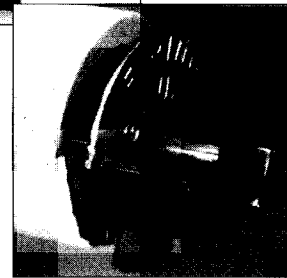

Figure 3

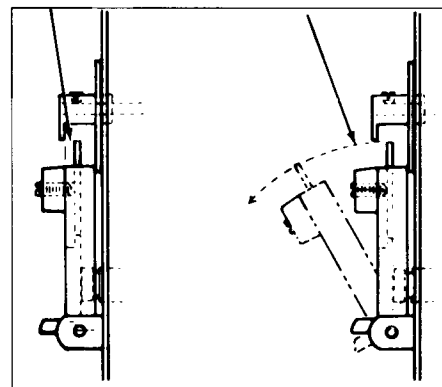

Figure 4
Set claw $\frac{1}{16}$ inch
from trigger
as shown

Figure 5
Set trigger to
just clear claw
as shown

The setscrew in front of the weight may be loosened to raise or lower the trigger, but it must be firmly retightened or the force of repeated falling of the weight may cause the trigger to creep out of adjustment (see Figure 6).

5. Check travel of sensing rod.

Remove the firing gauge and keep it for future periodic adjustments. The sensing rod is now free to travel vertically within the center of the tube cavity (see Figure 7).

By holding a small mirror inside the kiln so you can see the path of the sensing rod and by pressing down on the claws, you can easily check the movement of the rod within the tube cavity. It should not touch the sides at any point.

If necessary, the sensing rod can be centered by loosening the two guide plate screws or the front of the ASD and moving the guide plate to the right or left, as required. Be sure guide plate screws are firmly retightened (see Figure 8).

Note: This ASD adjustment should be repeated once every 20 firings or once every month.

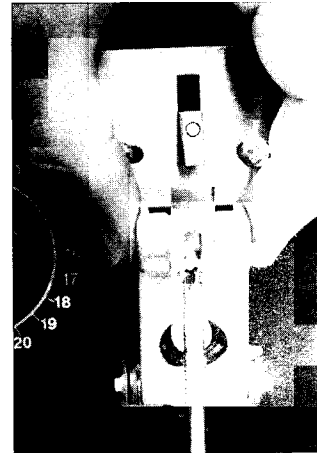

Figure 6

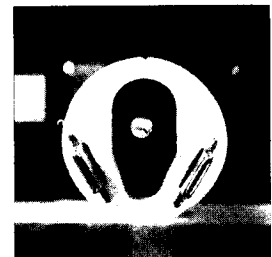

Figure 7

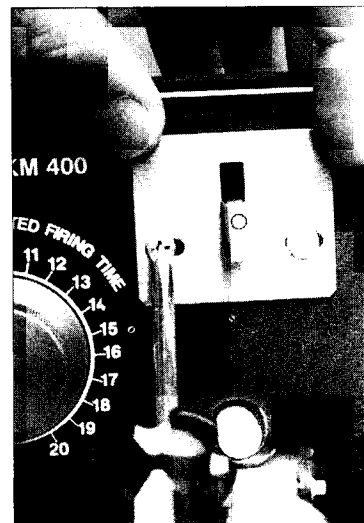

Figure 8

Description of Parts

The walls, lid and bottom of the kiln are made of insulating brick that helps keep the heat produced by the elements inside the kiln and allows heat to build up to the required temperatures.

Most wall bricks are grooved to hold and support the elements. The wall bricks are not cemented together but are held in place by the pressure of the kiln case. With use, fine cracks may form in the brickwork. These cracks close up during firing and open up as the kiln cools, serving as expansion joints.

Kiln brick is extremely fragile and will chip or crack easily. Never lean on the brick surface when loading the kiln for firing. If chips appear in the kiln lid, repair them immediately to prevent them from becoming larger.

Sometimes the kiln bottoms are damaged due to glaze drippings. If glaze drippings accumulate, scrape them off and apply a new coating of kiln wash. If you accidentally create holes in the floor when cleaning these drippings, mix kiln wash to a paste consistency and fill the hole, allowing the paste to dry before firing.

Most kiln bottoms are reversible and may be turned over if one side becomes too damaged.

Elements

The kiln's heat is produced by electric elements (coiled wires) set in grooved wall brick (see Figure 9). During firing, these elements are very soft, but they become extremely brittle when they cool and should be handled very carefully. When you turn your kiln on, the elements will normally hum for a short time.

Take care to prevent foreign materials—especially glaze, silica sand, alumina hydrate and kiln wash—from coming into contact with the elements and ruining them. Keep the kiln clean by regular vacuuming, as excessive brick dust in the element grooves will shorten the elements' life span.

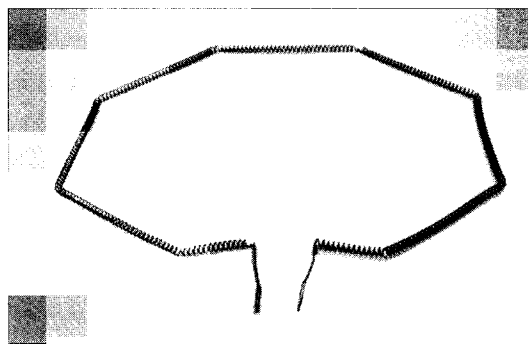

Figure 9

Peepholes

Peepholes allow you to look into the kiln firing chamber and determine the progress of your firing by checking the witness cones and the kiln's interior.

Peepholes have a secondary function in that they draw oxygen into the kiln, preventing reduction, and carry off smoke and water vapor.

Peephole plugs are used primarily to stop drafts from entering the firing chamber. It's not necessary for the peephole plugs to fit tightly, as some air should enter the kiln at all times.

During firing, never unplug a peephole for more than a few seconds, as this can cause a draft in the firing chamber, which could chill the witness cones, causing them to bend incorrectly: or fracture the ware near the peepholes. Care should be taken when looking into the peepholes so that the heat radiated from the firing chamber does not harm your eyes, face, glasses or contact lenses. Dark glasses are a good protective device and will also make the witness cones easier to see.

If you look into the kiln's peephole, places that are near the same temperature will be the same color. Brighter objects are hotter than darker objects.

Lid Vent Hole

The lid vent hole permits the continuous escape of moisture and gases from the kiln chamber during the firing cycle.

It should be left open during the entire firing cycle on bisque, glaze and overglaze firings (below cone 04).

If desired, the lid vent plug (available from a Duncan Distributor) can be inserted into the lid vent hole after two hours on the HI-FIRE setting for porcelain and stoneware firings. Use caution when inserting the lid vent plug as extremely hot air rises through the hole. A heat-resistant glove is recommended.

Lid Vent Prop

The DB 609 kiln's fall-away lid vent prop vents the lid in two stages. To close the lid after venting, lift the lid handle an inch. The lid vent prop will fall down by itself. Lower the lid gently as the warranty does not cover damage to the kiln or ware due to a dropped lid.

Ceramic pieces release gases and water vapor during firing. Venting allows these gasses to escape from the firing chamber. Do not rush the cooling of your kiln with the lid vent prop. This can damage your ware.

Safety Timer

This is a back-up, shut-off device designed to protect your kiln against severe overfiring damage if the ADS fails.

The numbers around the safety timer knob indicate hours of firing time. Since the safety timer will override the ASD, your timer should always be set for one-half hour longer than the estimated firing time. When that period of time has elapsed, the safety timer should turn off the kiln if the ASD has failed to do so, whether the ware is mature or not.

Lid Safety Switch (export models only)

If the lid is accidentally raised during kiln operation, the lid safety switch will interrupt power to the kiln. On some models, it releases the ASD plunger. If this is the case, follow these steps to continue the firing cycle: Turn all infinite switches off; make sure lid is closed; check the time remaining on the safety timer; push in the plunger; and return infinite switches to the position they were in when the lid was raised.

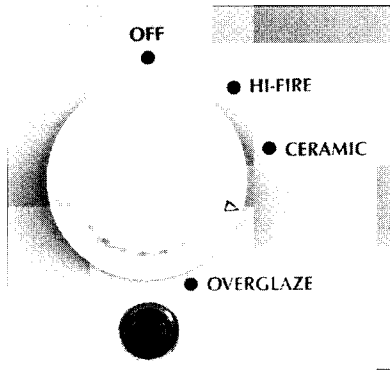

Switches

Each switch controls a group of elements. On models with more than one switch, the top switch controls the top set of elements and the bottom switch controls the bottom elements.

These switches are infinite: As you turn the knob counterclockwise, the heat increases by degrees. The switches cycle on and off, causing a slight, intermittent popping noise. The amount of “on” time increases as the switch setting increases until, at the HI-FIRE setting, the switch is on continuously.

The switch settings have been developed to compensate for the natural rise of heat to the top of the kiln. Therefore, on kilns with more than one switch, the top switch marking positions are different from the bottom ones. If your kiln should develop a tendency for the top to be hotter or cooler than the bottom, adjust the switch settings to correct the problem.

For more information on the setting, see **Standard Switch Locations** below.

Standard Switch Location for Firing

Overglaze refers to a decorative finish (gold, luster or decal) applied to a fired glaze surface and then fired to a witness cone range of 020 to 016 or cooler (see Figure 10).

Ceramic refers to ceramic articles or glazes fired between the witness cone ranges of 07 to 01 (see Figure 11).

Hi-Fire refers to ceramic articles or glazes fired to witness cone 1 or hotter for porcelain or stoneware (see Figure 12). *Note:* Do not go over the kiln’s maximum cone rating.

Since different clays and glazes require different firing conditions to mature properly, their manufacturer will recommend the appropriate witness cone.

Pilot Light

The small light above the ASD is on continuously when the plunger is in, indicating there is power to the kiln.

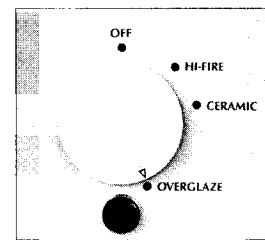

Figure 10 – Location #1

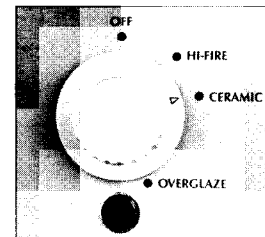

Figure 11 – Location #2

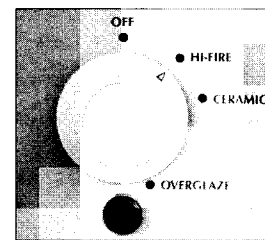

Figure 12 – Location #3

7

Kiln Furniture

Shelves & Posts

Shelves and posts are used to divide the kiln's interior for efficient use of its space. A kiln shelf is a flat slab of fired clay that has been fired to a higher temperature than will be encountered in your kiln. If firing cone 6 or hotter, we recommend our line of High-Fire Shelves. To protect your kiln floor against possible damage from glaze overfiring, never put glazed pieces directly on the kiln floor. A shelf placed on the floor of your kiln is much easier and less expensive to replace than the entire kiln.

Kiln shelves are strong, but like other pieces of pottery and ceramics, they will break if dropped and should be handled carefully.

Don't throw away kiln shelves that accidentally break. They will come in handy as extra protection during special firings when you know the glaze might run. You can also use them partway across your kiln as half shelves, allowing a large or tall piece to extend up from a lower shelf.

Stilts are small clay supports with points on the upper portion to support glazed pieces during firing. Stilts cannot be used to support porcelain bisque, as they become embedded in the porcelain when heated to high temperatures.

Duncan offers a variety of superlative shelves, posts and stilts that offer maximum use and enjoyment of your kiln.

Kiln Furniture Kits

The kiln furniture in each kit is specifically selected for each model, with the needs and resources—both creative and financial—of the new kiln owner in mind. Each low-cost kit contains the kiln furniture best suited for the optimal use of your kiln right from the start.

Kiln Ventilation System

UL-Listed Accessory for Duncan Listed Kilns



Duncan recommends that all brands and makes of kilns should be fitted with an overhead canopy-type exhaust hood, or be kept near a window with an exhaust fan, because of the gases which can be released as a by-product of the firing process. Studio-sized kilns should not be fired in the work area unless the kiln is under a hood vented to the outside.

The Duncan Kiln Ventilation System is recommended for use with Duncan Kilns and is perfect for safety-conscious dealers. It removes fumes and odors from all types of kiln firings, including metallic overglazes, lusters and high-sulfur clays. It lets ceramists and students enjoy clean air while working in the same area where kilns are being fired. The Duncan Kiln Ventilation System comes with a two-year limited warranty on parts and labor.

Note: The Duncan Kiln Ventilation System is not available in Canada.

Cones

When firing ceramic ware, a ceramist does not speak in terms of temperature but refers to a specific cone number. Since different clays and glazes require different firing conditions to mature properly, cones are available in a series of numbers to allow for these differences.

Types of Cones

There are two types of cones needed for your kiln:

1. ASD cones (commonly referred to as kiln-sitter or smaller cones)

An ASD cone is placed in the ASD for each firing. It is a small cone or bar designed for this purpose. Duncan recommends the Orton Pyrometric Bar for your ASD (Figure 13).

2. Witness Cones (or shelf cones)

Witness cones should be placed behind each peephole and/or on each shelf.

A witness cone is sometimes known as a large self-supporting cone (see Figure 14) or a shelf cone.

Duncan recommends the Orton Self-Supporting Large Cones for your kiln. They should be placed at least 2 or 3 inches from the peephole to protect them from cool drafts and usually in a series that includes a **guide** cone, a **firing** cone and a **guard** cone.

The **guide** cone is one cone cooler than your desired firing cone and is placed at one end. It will signal the approach of maturity.

The **firing** cone is the cone to which you wish to fire and is placed in the middle.

At the other end is the **guard** cone, which is one cone hotter than the firing cone and which, if bent, means the kiln and ware have exceeded the maturing point recommended.

The cones must be positioned so the bending of one does not interfere with the bending of the others. One good way is to place them side by side in a line so they will all bend in the same direction (see Figure 15 for example).

While using three witness cones is recommended, you should always use at least one cone equal to your desired firing on each shelf.

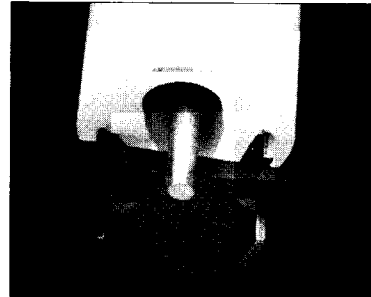

Figure 13 – Bar Cone: For the proper bar or cone to use, refer to the chart **Choosing Your Cone** on page 55.

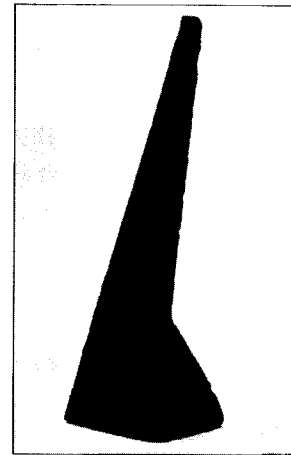

Figure 14

Witness Cone Interpretation

Did your firing reach the desired cone?
Use this guide as a reference.

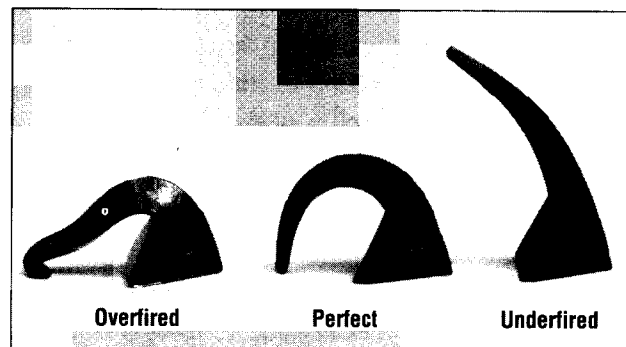

Figure 15

The most common causes of problems with a ceramic piece are the result of either underfiring (kiln shut off before reaching the desired cone) or overfiring (kiln shut off after exceeding desired cone). See **Conversion Table for Pyrometric Cones** on page 56.

An ASD bar or cone by itself will not guarantee that your firing achieves the desired cone. This is especially true when the ASD is out of adjustment. Placing a witness cone on the shelf with the pieces indicates the actual cone achieved during the firing. In most cases, if a poor result was caused by underfiring, you can readjust your infinite switch knobs and fire the piece over again using new cones (see **Standard Switch Location**, page 9). Pieces that were overfired cannot be corrected by refiring.

The products used by most ceramists have a firing range, rather than an exact maturing point. So, if the appearance of your glaze or ware is satisfactory and your firing cone is bent within the range shown (see Figure 15), your piece is properly matured.

Cones as Insurance

Shut-off devices are convenient and pyrometers help supply temperature information, but they are not substitutes for cones. Cones do more than measure temperature, since they bend as a result of the combined effects of time and temperature. In addition, cones provide a valuable safeguard against any failure of mechanical or electrical equipment. Pyrometers and shut-off devices occasionally malfunction, but by observing pyrometric cones, the ceramist can readily tell when such a malfunction is occurring.

Pyrometers periodically need recalibration; cones set within the kiln will tell the ceramist when the pyrometer is giving an inaccurate reading. If you do use some device, be sure to read the instructions provided with the device and frequently check its accuracy of operation by using pyrometric cones.

The Right Cone for the Job

As mentioned, we use the small cones for controlling the kiln-sitter. The cone used in a kiln-sitter will not react to heat exactly as it would if placed in the upright position and observed through a peephole. The weight of the actuating rod and the horizontal position cause the cone to bend at a lower temperature than one in an upright position. Many manufacturers recommend that you use one cone hotter in your ASD than you would when firing on an observation basis to allow for this variance (example: Use an 05 cone in the ASD for an 06 firing). If using a pyrometric bar, use the same cone number as in ASD. Be sure to consult the chapter on "Shut-Off Devices" for cone placement.

During your first few test firings in an empty kiln, place a cone of the same number used in the ASD in an upright position as close to the ASD as possible to measure the actual shut-off point of the ASD. This will tell you whether you are firing to the desired time and temperature. You will not be able to watch the cone during firing, but after the kiln has cooled to the touch you can open it, compare the original upright cone to the bent one in the kiln-sitter, and see if any adjustment is needed in the period of time between changing switch positions. (See **Test Firing** on page 19).

This same test should be conducted using a loaded kiln as well, until you get a good log or firing record formulated and you know exactly how your kiln reacts to different types of loads.

Time and Temperature

It must be pointed out that cones are not temperature-measuring devices. The specific function of a cone is to measure the combined effect of temperature and time because these factors determine when a glaze or clay has received proper heat treatment. Generally, the slower the rate of heating, the lower the bending temperature of the cone; the faster the heating rate, the higher the bending temperature. As a result, cone temperature equivalent charts are only true when the precise published temperature rate is maintained throughout the firing. With this in mind, temperature equivalent charts, whether published or printed on pyrometer dials, are to be used only as guides.

Choosing Your Cone

Choosing the right cone is very important. Use the chart on page 55 as a general guide to selecting the right cone. Always check the label on the jar for specific directions as there are exceptions.

Cones 4 through 12 are used in the firing of porcelain, floor tile, china, stoneware, structural clay products and some refractories. Approximate temperatures range from 2175° to 2459° F. or 1180° to 1340° C.

Record Keeping

It's good practice to keep a log book of all firings with the bending of the cones described by the "clock method" and their position in the kiln. The "clock method" describes the position of the cone tip in relation to an imaginary clock. In the unified position, it would be 12 o'clock, 1 o'clock, etc. to 6 o'clock as the end point. This log will become a valuable tool for duplicating desirable firings and diagnosing firing problems (see **Firing Record** on page 59).

9

Kiln Wash

Kiln wash is a protective coating applied to the top of the hearth plate (any shelf on the bottom of the kiln) and to the top of the kiln shelves to prevent any glaze drips from adhering permanently to these surfaces.

When the surfaces of your kiln floor or shelves protected by kiln wash become rough, scrape them off and add a new coat.

Kiln wash is usually purchased in a powdered form and mixed with water until it reaches the consistency of skim milk. Using a standard paint brush (2" to 4" wide), apply a coat of the kiln wash mixture to the top of all shelves including the hearth plate. Clean your brushes with soap and water, or Duncan Hand and Brush Cleaner.

Never apply kiln wash to the side walls, lid or bottom of shelves, as it will fall off during firing and ruin your glazed ware.

10

Pyrometer

A pyrometer consists of a meter with a temperature scale and a thermocouple inserted into the kiln to measure temperature. The pyrometer can be used as a guide for advancing switches or for gauging the cooling of the kiln, about which the cone tells nothing. The meter is *not*, however, an accurate way to determine the maturity of the ware and should never be used in place of witness cones because it measures only temperature. *Time, as well as temperature, is critical to properly mature ceramic ware*; therefore, only the witness cones on the shelf can record maturity correctly. If a firing is controlled solely by means of a pyrometer, the ware could easily be underfired. Your kiln case already has a hole for the thermocouple, so simply drill the hole through the brick and insert the thermocouple several inches into the chamber. Complete installation instructions are included with the pyrometer.

Loading the Kiln

Before loading, make certain all kiln switches are off, the inside of the kiln is free of dust (vacuuming also removes black metallic dust caused by ASD deterioration) and that the tops of all shelves (including the hearth plate) are coated with kiln wash.

Make certain you have properly placed a bar or small cone in the ASD before loading the kiln.

Only bone-dry ware should be loaded in your kiln. Damp ware may crack during firing and sometimes even explode, which could damage other ware and the elements. Greenware should be air-dried for approximately two days after casting, depending on the size of the piece and the humidity in the air. Glazed ware should dry four to six hours before firing. Drying should not be hastened by placing the pieces on the top of the kiln, as this may crack or warp them. Firing wet glazes may cause pinholes, cracking or bubbling. If this happens, try refiring the piece.

Three posts are used to support each shelf. Before positioning a shelf on the posts, make sure that the shelf clears the ware by at least one inch. Place posts of the proper size and length on the shelf prior to placing ware (see Figure 16).

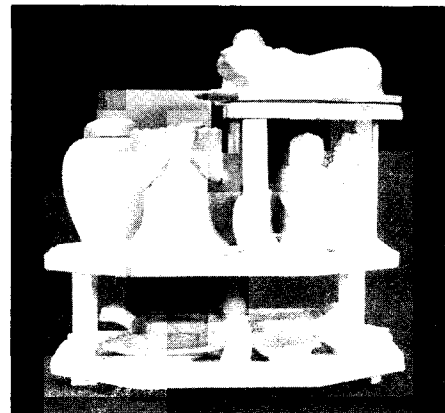

Figure 16

Lower shelves into the kiln carefully so as not to damage its walls or the ASD tube. Place shelves so you have at least one element between the shelves and one element between the top shelf and the top of the kiln.

Keep shelves and ware at least one inch from the ASD sensing rod and $\frac{1}{2}$ inch from the wall of the kiln. Plan your load and shelf arrangement before actually loading. Since dropped ware or shelves can damage the inside of your kiln, always load carefully.

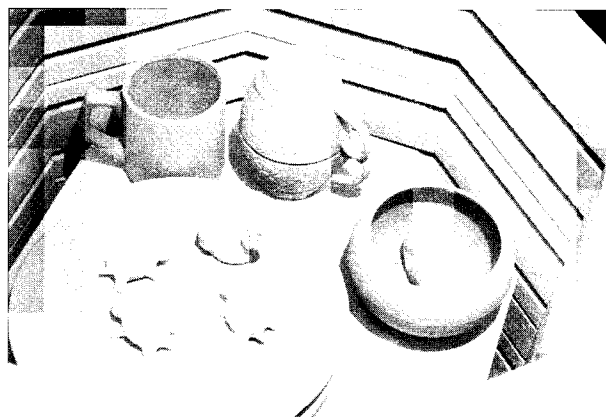

Figure 17

Try to place your heaviest load of ware in the kiln layer with the most element grooves.

Try to keep ware of the same relative height on one shelf to fully utilize the space. Mix light and heavy pieces on the same shelf; this will help the kiln heat evenly (see Figure 17).

Be careful not to jar your kiln after loading, since your ware could be broken or your ASD bar or cone could be dislodged.

Place witness cones on each shelf, preferably behind each peephole.

Large flat pieces should be placed so their edges are between elements. This will prevent the edges from heating before the centers and may eliminate possible cracking.

Warped ware can be caused when the piece is removed from the mold, or fired too close to the elements, or fired in an unnatural position.

Glazed ware and bisque ware should not be fired together unless both mature at the same cone. Even then, be sure the glaze piece is loaded in the bottom of the kiln.

The average cast piece can be fired on a fast-firing schedule. Slow firing of heavy pieces reduces the danger of breakage, and many people feel slow firing produces better ware.

Hand-modeled pieces should be fired alone and on a slow-firing schedule.

You cannot use a clock in lieu of a cone to time your firing. All Duncan kilns come with a limit timer that will shut them off to prevent overfiring, but time does not control accurate firing. Remember: The heavier a kiln is loaded, the longer the firing cycle. Duncan automatic kilns are designed to operate two hours on low. You can easily bypass your kiln's programming by using the override switch (see **Firing The Kiln**, page 21).

The amount of kiln furniture you use in loading a kiln will also affect the firing time.

Be sure your hands are clean when loading your kiln. Oil or dirt from hands may mix with colors and ruin the final finish.

Loading Greenware for Bisque Firing

Greenware pieces can touch each other, be nested or even stacked, as they will not adhere to each other when fired. However, if you stack, be sure not to strain the rim of any piece, place heavy pieces on fragile ones or stack them so compactly that heat cannot penetrate to the center of all the ware. Greenware can be placed directly on shelves; stilting is not required.

Generally, ware should be fired in its natural position except for pieces with flat vertical surfaces, such as wall plaques and clocks. These should be fired flat to prevent warping. Thin cups can be fired upside down or a pair stacked lip to lip to prevent deformation. Pieces with lids should be fired with the lids in place to ensure a good fit.

Loading for Glaze Firing

Glazed pieces may not touch or they will bond together permanently. Allow at least ½ inch between pieces so they will not contaminate each other during firing (when bubbles form and gases are released).

The tops of shelves should always be covered with kiln wash and the undersides of the shelves should be clean, as dust or particles falling on the ware may cause imperfections in the glaze finish.

Glazed ware must be stilted or dryfooted (not glazing the area where the ware will sit on the shelf) to keep it from sticking to the shelves. Stilting is the preferred method for low-fire (cone 04, 05 or 06) glazes. To avoid glaze buildup on stilts, coat the stilts with kiln wash.

Do not place greenware and glazed ware in the same load, as they mature at different cones and the gases in the clay body of the greenware can cause glaze discoloration.

If you plan to refire a glazed piece and need to stilt it, coat the bottom of the piece with a light coat of clear glaze. This will give the bottom texture and keep it from slipping off the stilts.

Loading for Overglaze Firing

The same rules apply for loading an overglaze firing as for loading a low-fire glaze firing. Special care should be taken to allow at least one inch between pieces decorated with lusters so they will not contaminate each other during firing.

For DB 609 Hobbyist Kiln, the lid may be propped to its second position for additional venting if desired. However, the hole in the lid adequately vents most loads and you can leave the lid closed and the peephole plugs out for most firings.

Loading Porcelain for Bisque Firing

Porcelain is a high-fire clay body that vitrifies (becomes nonporous) when fired. In its natural state, porcelain varies from white to light gray; however, a wide variety of colored porcelain bodies are available.

The tops of all shelves must be coated with Duncan Kiln Wash, which is formulated for high-fire usage.

Some pieces (for instance, a teapot with a spout and handle) are likely to sag in a porcelain firing. Hand-formed rolls of the same clay body can be used to support the parts that may sag. To prevent them from fusing together during firing, apply alumina hydrate to the rolls where there is contact with your ware. To remove Duncan's kiln coating, wash each piece after firing and use an abrasive scrubber.

Simple shapes such as plates can be supported by commercially made setters designed for particular articles. Again, kiln wash must be applied.

When firing greenware pieces with lids, apply alumina hydrate to the pieces at any point where contact is made.

Load the greenware carefully as it will stick together and has a tendency to distort in shape.

Never place a piece closer than $\frac{3}{4}$ inch from the side walls, as unequal heat tends to increase the possibility of distorting the shape.

Stilts should not be used to support porcelain clay bodies because the clay becomes very soft in the process of maturing and will adhere to the stilts.

Loading Porcelain for Glaze Firing

Any glazed ware should be dryfooted. Pieces that require support during the bisque firing will not require support during the glaze firing, because the lower temperature requirement will not produce sagging.

Loading Stoneware for Bisque or Glaze Firing

Stoneware is a high-fire clay body that normally vitrifies (becomes nonporous) when fired and has a range of textures and natural colors.

Greenware items can be stacked on top of each other since they will not adhere to one another when fired; still, be careful not to strain the rims. Greenware can be placed directly on shelves; stilting is not required. Be sure your items are bone-dry. Dampness in the ware can cause pieces to crack and even explode.

Loading Stoneware for Glaze Firing

For a glaze firing, the tops of the shelves must be coated with Duncan Kiln Wash and the ware is always dryfooted rather than placed on stilts.

Test Firing

12

Before you load a new kiln with ware, it's important to run two preliminary firings. One is to ensure your ASD is operating properly, and the other is to build up a good oxide coating on the elements.

Your new kiln should be cleaned thoroughly before firing. This can best be done with a nozzle attachment to a vacuum cleaner or a damp cloth or sponge.

When firing your kiln, you may hear a humming noise; this is normal. It will only last for a few firings and is commonly caused by element vibration.

ASD Test

The ASD mechanically shuts off your kiln when the pyrometric bar or small cone in the mechanism bends. Because the ASD is such an important device, make sure it's operating properly before doing any firing. Use the following ASD instructions and the 019 bar and cone provided with your kiln to perform this test:

1. Remove firing gauge (see Figure 18).
2. Turn off all kiln switches. The life of the ASD will be increased if kiln switches are off before engaging the ASD.
3. Kiln wash should be applied to top of cone supports and bottom of the sensing rod.
4. Raise weight up against guide plate.
5. Press claw down lightly until it engages trigger.
6. Insert pyrometric bar or small cone in the ASD and place witness cones on the shelves, as described on page 12.

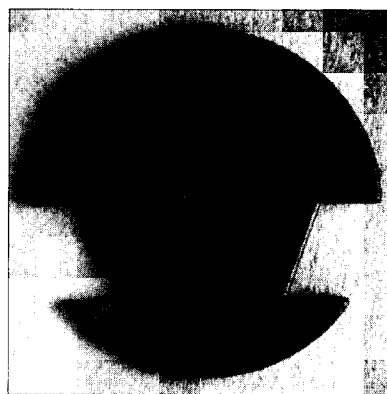

Figure 18

While holding the claw down, center the pyrometric bar on the cone supports (see Figure 19). If a small cone is used, carefully place the cone under the sensing rod with a flat side on the cone supports. The cone should be against the metal step of the cone supports, with the center of the cone parallel to the end of the tube.



Figure 19

Generally, you will find that a small cone in the ASD needs to be one cone hotter than the firing (witness) cone on the shelf to obtain correct results. While this is particularly true for cones 06, 05 and 04, test your kiln; it may act differently, depending on the ASD adjustment and the desired firing (witness) cone. For example, if your desired result is a witness cone 04, you would use an 03 pyrometric cone in the ASD.

If you are using a pyrometric bar, use the same cone number as in the ASD. For the cone 019 test firing, the 019 ASD bar will usually result in a fully matured 019 firing (witness) cone.

If a pyrometric cone is used, you can vary the shut-off temperature slightly by the way the cone is positioned in the ASD. If the cone is moved so that its thinner section is under the sensing rod, shut-off will occur sooner than when a thicker section of the cone is under the rod. Either way, make certain you have at least 1/16-inch of the cone overhanging the cone support on each side to prevent an early shut-off.

7. Close lid.
8. Turn safety timer knob clockwise to appropriate time: 2-3 hours.
9. Push firmly on the plunger until it locks.
10. Fire the kiln according to **Standard Switch Locations** instructions on page 9. During the cone 019 test firing, the ASD weight will drop in approximately 2-3 hours, shutting off the kiln.

When the kiln is cool to the touch, you can open it and inspect the cones. If you've made all your adjustments correctly, the ASD bar or cone will be bent to an approximate 90° angle and your firing (witness) cone will be bent within the range shown on page 11.

Preliminary Cone 05 Firing

This firing is necessary to allow a coating of oxide to form on the elements before any ware is fired.

Place the witness cone on the hearth plate.

Do not fire any ware: A pure atmosphere in the firing chamber is necessary to allow a good oxide coating to form on the elements. This is important, for a good coating increases element life.

CAUTION: Since the ASD bar or cone is the triggering element that normally shuts off the kiln, its correct positioning is important for proper firing. *If the bar or cone is dislodged by accident or allowed to come in contact with the porcelain tube, an overfiring could result, causing serious damage to your kiln.*

Set the safety timer for six hours for this firing. Now follow the instructions on the kiln which are also described in **Standard Switch Locations** on page 9. Under ideal conditions, the firing will take four to six hours; *abnormally low voltage, however, can lengthen the firing time.*

When the kiln shuts off, record the length of time it took to fire. This information will help you estimate firing times in the future, although a loaded kiln will take longer to fire than an empty one.

Do not be concerned about odors during this or the next few firings; they come from the elements and moisture in the brick or ware.

Firing the Kiln

13

The override switch is the 1 $\frac{3}{16}$ " x $\frac{9}{16}$ " black three-position switch located above the ASD.

The override switch allows you to either fire the kiln automatically, as designed, or manually.

Firing Instructions for the AUTOMATIC Mode:

1. Set override switch to the AUTOMATIC position.
2. Turn the one or two infinite switches (white knobs) to the OFF position.
3. Place desired cone in the ASD.
4. Load kiln, placing desired witness cone on each shelf.
5. Close lid; do not prop.
6. Insert all peephole plugs.
7. Set safety timer.
8. Push in ASD plunger.
9. Turn infinite switches to desired firing of overglazes, ceramics or high-fire (see Standard Switch Locations, page 9).

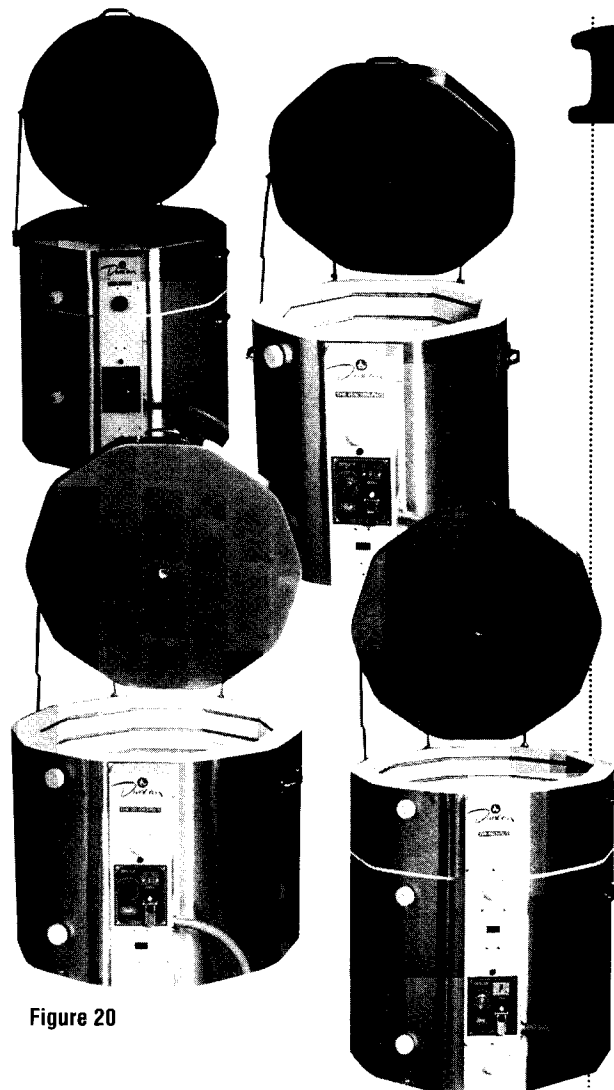

Figure 20

In the automatic mode, the kiln is on LOW for two hours and then will switch itself to the infinite switch settings from Step 9 for the remainder of the firing cycle.

Firing Instructions for the MANUAL Mode:

When to use the manual mode:

- A. When you want to fire on LOW for more than two hours (soaking) or for less than two hours.
- B. If you want the kiln set at HIGH from the beginning of the firing cycle (fast firing).
 1. Set override switch to the LOW position.
 2. Turn the one or two infinite switches (white knobs) to the OFF position.
 3. Place desired cone in the ASD.
 4. Load kiln, placing desired witness cone on each shelf.
 5. Close lid; do not prop.
 6. Insert all peephole plugs.
 7. Set safety timer.
 8. Push in ASD plunger.

9. Turn infinite switch or switches to desired firing for overglaze, ceramics or high-fire. The kiln will remain on LOW for as long as the override switch is in the LOW position (see **Standard Switch Locations**, page 9).
10. When you want the kiln to go to HIGH, simply switch the override switch to the HIGH position. The kiln then will switch itself to the infinite switch settings from Step 9 for the remainder of the firing cycle.

If you wish to have the kiln on HIGH for the entire firing, set the override switch to the HIGH position in step 1 of the manual-mode firing instructions.

Firing steps for DB 1027-2 (Potter Kiln Only)

1. Turn all switches to Low. Fire for two hours.
2. After two hours on low:

When Firing	Turn Switches to
Overglazes Gold, Decals, Lusters (cone 022-016)	Medium
Bisque or Glazes (cone 06-02)	High
Porcelain or Stoneware (cone 2 or hotter)	High-Fire

Firing steps for DB 609 (Hobbyist Kiln Only)

		START	1/2 HOUR FROM START	1 HOUR FROM START	1½ HOURS FROM START
China paints, Gold and other Overglazes	KILN SWITCH	Low	Low	Medium	High
	PEEPHOLE PLUG	Out	Out	Out	In*
	LID POSITION	Vented	Vented	Vented	Closed*
Low-Fire Greenware and Glaze	KILN SWITCH	Low	Low	Medium	High
	PEEPHOLE PLUG	Out	Out	Out	In*
	LID POSITION	Vented	Vented	Vented	Closed*
Porcelain or Stoneware Greenware and Glaze	KILN SWITCH	Low	Medium	High	
	PEEPHOLE PLUG	Out	Out	In*	
	LID POSITION	Vented	Vented	Closed*	

* Do not close lid until all odor of china paint oils or burning lace has gone. Leave peephole plugs out until no vapor can be detected by holding a hand mirror in front of the top peephole.

Cooling & Unloading

14

The cooling period is very important. If the lid is opened before the kiln is sufficiently cool, there is a good chance you will **damage** both the ware and the kiln. Before opening the kiln, allow it to cool at **least twice as long** (or longer) than it took to fire.

Unload the kiln only if the pieces are cool enough to handle with your bare hands. Removing pieces too soon will cause cracks in ware and singed fingers. As you unload, check the firing cone on each shelf to determine if the ware or glaze has properly matured; it is always advisable to refire underfired ware.

If you find your glazes seem to pull away from the bisque after firing (crawling), you may have overfired.

Your underglazes may run if you overfire. You may also find you're applying glazes too heavily and they're "pulling" underglaze from the surface.

When **unloading** a glaze firing, remove the stilts from the ware. Handle the ware carefully and check for **stilt marks**. These are sharp and should be ground off with an abrasive stone.

Firing Hints

15

The length of time your firings take depends upon the thickness of the ware, the size of the kiln, the amount of ware in the firing chamber and voltage variations. Your kiln's firing time will also increase as the elements age. Do not rush a firing; this could create unnecessary problems (see **Recognizing Firing Faults** on page 24).

We recommend that you record each of your firings (see **Firing Record** on page 59). This practice will enable you to duplicate your successful firings, avoid unsuccessful ones and record the results of any modifications you incorporate into your procedures.

Stopping a firing prior to maturity will not hurt your ware. If the kiln is jarred or if you think a piece of ware has fallen over, don't risk ruining the entire load: Turn the safety timer off to stop firing the kiln.

If your kiln shuts off before the ware is mature, the safest thing to do is to cool your kiln, set fresh cones and refire as usual.

16 Firing Faults

Imperfect ceramic articles usually result from incorrect color application, improper firing or lack of information. The following chart lists some of the common faults that can result from improper firing. There are other problems that can occur which may or may not be related to your kiln. For information on these, check your color manufacturer's or supplier's literature.

RECOGNIZING FIRING FAULTS

SYMPTOMS	PROBABLE CAUSE	REMEDY
Cratered or Bubbled Glaze	<ol style="list-style-type: none">1. Underfiring.2. Glaze application too thick.3. Immature bisque.	<ol style="list-style-type: none">1. Grind down the bubbles, add a thin coat of glaze and refire to proper firing cone.
Crazing	<ol style="list-style-type: none">1. Underfired or immature bisque.2. Kiln cooled too rapidly.3. Thermal shock (removing piece from kiln too soon or subjecting it to extreme temperature changes).4. Improperly formulated body.	<ol style="list-style-type: none">1. Sometimes can be corrected by refiring the piece one cone hotter than the original glaze firing.
Cloudy Transparent Glaze	<ol style="list-style-type: none">1. Glaze applied too heavily.2. Not fired hot enough.	<ol style="list-style-type: none">1. Refire to proper firing cone.
Grayed or Discolored Glazes	<ol style="list-style-type: none">1. Ware placed too close to element.2. Overfiring.3. Insufficient application of glaze.4. Fired with incompatible colors or greenware.5. Applied to greenware.6. Insufficient ventilation during firing.	<ol style="list-style-type: none">1. Although difficult to correct, sometimes refiring to the proper firing cone will work.2. Try applying a heavy coat of glaze and refiring, if Remedy #1 doesn't work.3. Glazes that have grayed usually cannot be salvaged.
Shiny Matte Glazes	<ol style="list-style-type: none">1. Misfiring, either overfiring or underfiring, depending on glaze composition.	<ol style="list-style-type: none">1. If underfired, refire to proper firing cone.2. If overfired, this is difficult to correct. Sometimes applying another coat of glaze and refiring will help.
Pinholes	<ol style="list-style-type: none">1. Underfired bisque.2. Dust left on ware or in the kiln.3. Glaze was applied to greenware.4. Firing too rapidly.5. Improperly adjusted slip.	<ol style="list-style-type: none">1. Refire to proper firing cone.2. Apply a thin coat of glaze before refiring.3. Problem best remedied before glazing. Properly adjust slip with silicate of soda, properly fire and clean bisque.
Smooth Texture Glazes	<ol style="list-style-type: none">1. Insufficient application.2. Misfiring.	<ol style="list-style-type: none">1. Reapplying glaze and refiring to proper cone will usually correct the problem.
Distorted Bisque	<ol style="list-style-type: none">1. Overfiring.2. Ware incorrectly removed from the mold.	<ol style="list-style-type: none">1. Saving these pieces is usually impossible.

RECOGNIZING FIRING FAULTS, continued

SYMPTOMS	PROBABLE CAUSE	REMEDY
Cracked Metallic Overglazes	<ol style="list-style-type: none">1. Overfiring.2. Too heavy an application.	<ol style="list-style-type: none">1. Refire object to cone 06 to burn off the overglaze, then apply another coat and refire to the firing cone recommended by the overglaze manufacturer.
Faded Decals	<ol style="list-style-type: none">1. Overfiring.2. Underfiring.	<ol style="list-style-type: none">1. If decal was overfired, the problem cannot be corrected.2. If decal was underfired, refire to the proper firing cone. <p>Note: In both cases, check the manufacturer's firing recommendation to determine over- or underfiring.</p>
Blistering During Decal Firing	<ol style="list-style-type: none">1. The decal firing was too hot, causing the glaze to start to react.	<ol style="list-style-type: none">1. Saving these pieces is usually impossible.

17

Standard Kiln Maintenance

Although the kiln is one of the most vital and expensive pieces of equipment a ceramist can own, it is often abused, misused and neglected. You can enjoy many extra years of firing if you understand your kiln and treat it with respect.

Careful attention to the following preventive-maintenance instructions will greatly increase your kiln's life span.

Every Loading

1. Check the ASD's sensing rod and cone supports.

Check the rod for free and centered travel. This can be done as you place the bar or cone in the ASD. If movement is sluggish, follow the **Tube Assembly Replacement** procedures on page 46.

Continued operation at high-fire temperatures will eventually cause the cone supports and the end of the sensing rod to deteriorate or bend—in turn affecting the adjustment between the trigger and claw. If this occurs, both the rod and cone supports must be replaced.

Excess kiln wash must not be allowed to accumulate on cone supports. Keep the protective layer very thin; excess wash can be easily removed by hand. If any nonremovable materials accumulate, cone supports must be replaced.

2. Vacuum the kiln interior.

Examine the inside of the kiln to be sure it's free of dust. *For the best results, vacuum your kiln interior before every firing* or at least before each glaze firing, as floating dust will adhere to maturing glaze.

Your kiln will give you years of service if you care for it properly. It should not be considered a household appliance, but rather a piece of hard-working machinery. If you fire porcelain and use silica sand and/or alumina hydrate, keep it out of the element tracks by vacuuming after every firing. Failure to do this will cause the elements to wear out faster, a condition not covered by your warranty.

3. Check the kiln shelves.

The shelves do not have to be recoated with kiln wash for every firing, but an adequate coating should be maintained. Brush any loose particles of kiln wash from the shelves and check every shelf for cracks before placing it in the kiln.

Every 20 Firings or Monthly

1. Check ASD adjustment.

Due to heat, corrosion and mechanical wear, the ASD may slip out of adjustment over a period of normal use or the repeated fall of the weight could force the trigger to creep. To ensure consistent firing, carefully repeat the steps outlined on page 5.

2. Tighten the kiln case and lid band.

Due to the expansion and contraction of your kiln during firing, the clamps on the case will need to be tightened occasionally. Tighten them with a screwdriver when the kiln is cool.

Whenever Necessary

1. Remove glaze spots from shelves or kiln brick.

Whenever spots of glaze appear on either shelves or brick, they should be removed prior to the next firing. If this isn't done, the glaze will remelt and spread with every firing.

If the glaze spot spreads to an element on the side brick, the element will burn out. Dig the spot out of the side brick with a screwdriver or knife. Chip the glaze off the shelves (safety glasses should be worn) and touch them up with kiln wash.

After removing glaze, be sure to vacuum the firing chamber before firing.

2. Repair any badly damaged brick.

Small chips, dents and gouges in the brick don't need to be repaired as they don't affect the kiln's firing ability. However, any sizable damaged spot needs repair.

3. Clean the outside.

Although the exterior of your kiln will discolor with repeated firings, you can use a stainless steel cleaner to remove gas stains around the peepholes. Glass cleaner, meantime, should keep the stainless steel looking like new.

A clean exterior will not improve your kiln's firing ability, but it might increase its resale value and general appearance.

18 Kiln Repair

Repairing your kiln is very easy. This section offers helpful tips and explanations. In addition, many parts of the country have kiln representatives to assist you.

Troubleshooting

Caution: Your kiln has been built for many years of reliable operation but if you do have trouble, consult this chart for possible causes and remedies before you call a service person.

The following information may save you unnecessary costs. Note: Have all electrical wiring done by an authorized service person.

TROUBLESHOOTING

SYMPTOMS	PROBABLE CAUSE	REMEDY
SLOW-FIRING KILN Many times this is not a valid complaint.	New Kiln	
	1. Supply voltage lower than what kiln requires.	1a. Replace with proper kiln. <i>OR</i>
	2. Gauge of house wiring too small.	1b. If voltage is 110, consult electrician.
	3. Low service voltage.	2. Consult electrician.
		3a. Check with power company. <i>OR</i>
		3b. Increase heat setting and/or shorten firing schedule.
	4. Switch out of calibration.	4. Recalibrate or replace switch.
	5. Defective switch.	5. Replace switch.
	Sudden Increase in Firing Time	
	1. Unusually heavy load.	1a. Reduce amount of ware. <i>OR</i>
2. Loose connection in kiln wiring.	1b. Increase heat settings and/or shorten firing schedule.	
3. Loose connection in house wiring or wall receptacle.	2. Tighten connection; replace any damaged parts.	
4. Section of kiln not heating.	3. Consult electrician.	
5. Voltage drop (brownout).	4. See SECTION OF KILN DOES NOT HEAT in this chart.	
<i>Note:</i> See Control Circuitry Troubleshooting.	5. Check with power company.	
Gradual Increase in Firing Time		
1. Elements wearing out.	1a. Replace elements. <i>OR</i>	
	1b. Increase heat settings and/or shorten firing schedule.	
KILN WILL NOT REACH MAXIMUM CONE	See SLOW-FIRING KILN in this chart.	See remedies for SLOW-FIRING KILN listed in this chart.
KILN WARMS BUT DOES NOT ATTAIN RED HEAT	Wall receptacle wired incorrectly.	Dangerous; do not operate kiln until electrician has checked wall receptacle.

TROUBLESHOOTING, continued

SYMPTOMS	PROBABLE CAUSE	REMEDY
SECTION OF KILN DOES NOT HEAT	Pilot light on 1. Defective element. 2. Defective switch. 3. Loose connection in kiln wiring. 4. Broken connecting wire. 5. Relay.	1. Replace element. 2. Replace switch. 3. Tighten connection; replace any parts. 4. Replace wire. 5. Replace relay.
MIDDLE BANK OF ELEMENT NOT GLOWING RED	1. 1029N models when functioning properly are designed not to glow red.	
KILN WILL NOT HEAT AND PILOT LIGHT NOT ON	1. Kiln not plugged in. 2. ASD plunger not pushed in. 3. Blown fuse or tripped circuit breaker. 4. Defective ASD switch unit. 5. One or more leads from cord not connected to ASD.	1. Plug cord into appropriate wall outlet. 2. Push in plunger. 3. See FUSE BLOWS OR CIRCUIT BREAKER TRIPS in this chart. 4. Replace all or part of ASD switch. 5. Connect cord leads.
ONE SECTION OF KILN CONSISTENTLY FIRES TOO HOT OR TOO COOL	1. Some elements older than others. 2. Switch out of calibration.	1a. Change heat settings to compensate for unevenness. <i>OR</i> 1b. Replace old element. 2a. Change heat settings to compensate for unevenness. <i>OR</i> 2b. Replace switch.
KILN SHUTS OFF BEFORE FIRING IS MATURED	1. ASD out of adjustment. 2. Safety timer not set for enough time. 3. Wrong cone in ASD.	1. Adjust ASD. 2a. If kiln just shut off, reset timer and activate ASD. <i>OR</i> 2b. Cool kiln, refire with new cones and set timer correctly. 3. Let kiln cool; refire with correct ASD cone.
PILOT LIGHT OFF BUT KILN OPERATING	1. Pilot light or its connecting wire defective. 2. Loose connection.	1. Replace light. 2. Tighten connection.
FUSE BLOWS OR CIRCUIT BREAKER TRIPS First, reset breaker (or replace fuse) to be certain problem exists.	1. Short circuit in kiln wiring. 2. Overloaded circuit. 3. Inadequate, defective or improperly installed house wiring. 4. Defective circuit breaker. 5. Fuse box or circuit breaker located in place where it gets hot from kiln's heat.	1. Locate and correct short circuit. 2. Disconnect any other appliances from circuit. 3. Consult electrician. 4. Have electrician replace. 5. Move kiln to have electrician move wall receptacle.

Troubleshooting Equipment

Multimeter

A multimeter combines the features of an amp meter, volt meter and ohm meter into one instrument. Most multimeters require no external source of power. The power necessary for resistance measurements, common in kiln troubleshooting, is furnished by the meter's batteries. When used in kiln troubleshooting, most readings will be done on the ohm scale (element resistance, etc.) but occasionally, the need for volt readings will arise. In any event, the multimeter is the best way to ensure a kiln's electrical safety after a repair.

Scales

On the face of the multimeter are graduated scales for each of the unit's readable functions. Since the meter's needle is positioned slightly above the scale, an incorrect reading may occur when the needle is viewed from the side. To avoid this, the scale should be read from a position directly in front of, or above, the needle. Some meters have incorporated a mirror in the scale so that an incorrect reading may be readily seen, as the needle and its reflected image coincide when viewed from the proper angle.

The meter's ohm scale is not divided into uniform divisions. The largest divisions are usually at the right end, while the smaller divisions crowd in on the left end.

Zero-Set Adjustment Screw

Care must be taken that the needle is properly adjusted before using the meter. Most meters are equipped with a screw adjustment that mechanically sets the needle at zero on the left side of the scale.

Zero Ohms Control

This control adjusts the meter to compensate for battery aging when using the ohm scale. Set the range selector to the desired resistance range, touch the probes together and adjust this control until the needle registers zero ohms. If the needle cannot read zero on the ohm scale, the batteries need to be replaced.

Function Switch

In kiln troubleshooting, use the ohms position when checking resistance and the AC (alternating current) position when checking voltage.

Range Selector

The range selector allows the user to alter the meter scale so the expected reading falls within the scale and the greatest degree of accuracy is obtained. When reading ohms, it is best to use a range where the reading will appear in the most spread-out portion of the scale. When you need to read voltage, be extremely careful not to allow more voltage to flow through the meter than the meter is set for or the meter may be damaged. If the voltage is unknown, always start the highest range and work down until an acceptable reading is obtained. When the meter is not in use, the range selector should be placed in the OFF position or on a volt range.



Figure 21

Jacks

All meters have at least two jacks into which the test leads are inserted. Usually one jack is designated as common and used for all functions of the meter. If there are only two jacks, the other one would also be multipurpose. Sometimes, however, a meter will have a jack for each function. When reading ohms, either test lead can be plugged into either jack, but when voltage is being checked, the **negative (black) test lead must be connected to the negative jack (common)**, and the positive (red) test lead to the positive jack.

Setting Multimeter for Ohm-Scale Reading

1. Place meter in correct position (check meter's instructions) on nonmetallic surface to ensure most accurate readings.
2. Adjust zero setscrew so needle rests exactly over zero ohms at the left side of the scale.
3. Plug black test lead into common jack, and red into ohms jack.
4. Set function switch to ohms position.
5. Set range switch to lowest ohm setting, usually Rx1.
6. While touching test probes together, move the ohms adjust control so needle stabilizes over zero ohms. If needle will not reach zero, multimeter needs new batteries.

Setting Multimeter for Volt-Scale Reading

1. Place meter in correct position (check meter's instructions) on nonmetallic surface to ensure most accurate readings.
2. Adjust zero setscrew so needle rests exactly over zero volts at left side of scale.
3. Plug black test lead into common jack and red lead into volt (V) jack.
4. Set function switch to AC-volt position.
5. Set range switch on AC-volts range that includes expected voltage.

To prevent meter damage, do not allow voltage to flow through the meter at a higher level than the established level. If the voltage is unknown, always start with the highest range and work down until an acceptable reading is obtained.

When using a multimeter to read volts, the following cautions must be observed:

Only touch the insulated handles of the test probes. The test probes should come in contact only with item being tested. Do not allow them to touch each other or any other metallic surface.

A digital multimeter is also recommended (see the owner's manual from the manufacturer for instructions).

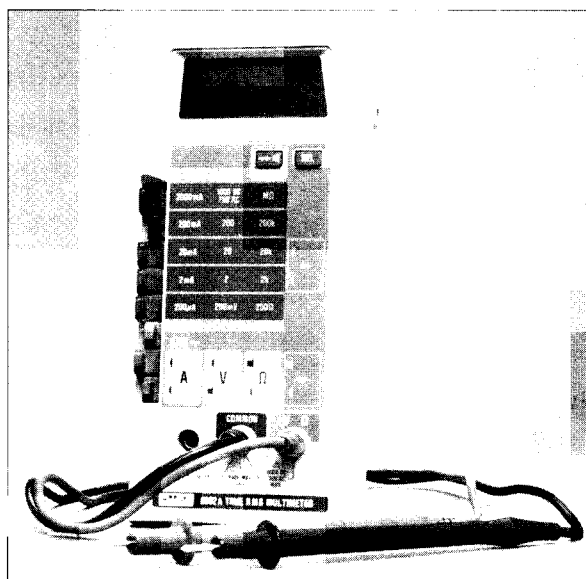

Figure 22

Control Circuitry Troubleshooting (Automatic Kilns)

1. Kiln acts as if it's on low all the time.
 - A. After checking elements, infinite switch, connecting wires and voltage, it could be the KM 325 (4300). (See Parts Schematic in your owner's packet.)
 - B. Try the two-hour test. Set the infinite switch to the off position. Set the safety timer for three hours on the ASD and push in the plunger. The kiln will make a click sound every 60 seconds for the next two hours. After two hours, the sound should stop. If not, replace the KM 325.
2. Kiln makes a loud chatter sound.
 - A. Turn the infinite switch to the off position. If the kiln does not stop until the ASD is turned off, replace KM 326. (See Parts Schematic.)

Spikes and Surges (KM 324 and KM 325)

In the Automatic kilns, the two timers are solid-state circuitry so they are susceptible to line spikes and surges.

Line spikes and surges are caused by many things: lightning, pump motors, sun spots, arc welding and so on. If there is a thunderstorm approaching, unplug your kiln. Spikes and surges may also affect the timers.

How Your Duncan Automatic Kiln Works

The KM 325 (4300) is a two-hour, delay-off timer that controls the KM 326 (4600) timer—which is a 60-second flasher that controls a relay.

The KM 326 turns the relay on and off every 60 seconds until the KM 325 turns it off. The relay is a normally closed relay, meaning that when it's off, power will flow all the time. The relays control the elements or an infinite switch (KM 300).

On the DA kilns, we use an override switch that controls both KM 325 and KM 326. In the manual low position, the kiln will cycle on and off every 60 seconds for as long as you like. In the manual high position, the kiln will not cycle and will bypass the warm-up. In the automatic position, the kiln will go through the two-hour warm-up and then remain on high until the kiln-sitter drops.

Control Panel

The control panel on a Duncan kiln houses the kiln's electrical components. It serves as the mounting surface for switches, ASD, etc., and its design makes the controls easy to see, operate and repair.

There is ample space inside the control panel to prevent the electrical connections from touching each other. This is important. It helps prevent short circuits that can be caused by wires touching when they should not, by wires or connectors with deteriorated or burned spots, or by loose connections or miswiring. Therefore, it is recommended that every time a control panel is removed, the wiring be carefully inspected. When replacing a control panel, all wires should be pressed toward the front of the panel to prevent contact with the heat shield or any other part.

Since heat is the number-one enemy of electrical parts, care was taken to incorporate as many temperature-reducing features as possible into the control panel design. The louvers in the control panel allow air circulation inside the panel, and the standoffs minimize direct heat transfer from the kiln case to the control panel.

The heat shield, as its name implies, protects the control panel from the heat radiated by the kiln. It creates a narrow, vertical, open-ended passageway that allows cool air to be drawn in at the bottom and hot air to escape out the top in a chimney effect. The heat shield is held rigidly in place by the insulators, bus bars and U-terminals; the one-inch hex-head, sheet-metal screw in the lower left corner ensures proper grounding.

Control Panel Removal

1. *Unplug kiln.*
2. Remove screws.
3. Carefully pull control panel off kiln until ASD tube is free; keep tube level so it will not gouge brick.
4. Disconnect wires attached to two lower switch terminals on each switch to free control panel.
5. Whenever control panel is removed, for any reason, it is advisable to:
 - a. Check all wiring for deterioration, burned spots, loose connections or other defects.
 - b. Check cord for frayed wires and any contact between lead wires.

Control Panel Replacement

1. Connect wires from elements to switches. Two top wires go to top switch, relay, etc. (See appropriate Electrical Schematic in your owner's packet).
 - a. Slip-on terminals should fit tightly when pushed onto switch tabs; they should not slip off and on easily.
 - b. If terminal is loose, tighten by gently squeezing terminal with pliers.
2. Carefully reposition control panel on kiln.
 - a. Route wire from lowest U-terminal connector to left of ASD tube as you face kiln.
 - b. Press all wires to front of panel so they will not touch heat shield or ASD tube, or be pierced by the ends of the elements.
3. Replace mounting screws.
4. Test kiln with multimeter for electrical soundness.
5. Check ASD adjustment.

Elements

Maintaining Element Life

A thin protective coating of gray-white alumina will form on the surface of iron-chromium-aluminum elements when fired in a pure oxidizing atmosphere above 1800° F. (the recommended cone 05 break-in firing). This layer of alumina is an oxide produced when oxygen in the air combines with the aluminum in the element. It is very important in prolonging the life of an element, retarding further oxidation of the element, and providing protection against attack from gases and fumes released from clay and glazes during firing.

Gradually, within the normal life of an element, the oxide coating will be destroyed and replenished until the aluminum content is reduced to practically nothing. Then iron-chromium oxide will form. The presence of this gray-black oxide indicates the element is nearly worn out.

Although it's difficult to generalize about the probable life of elements, they should last for many, many firings, providing no accident occurs within the kiln. Nevertheless, high-fire temperatures (porcelain and stoneware) will cause the kiln's elements to deteriorate at a faster rate. Those ceramists who fire their kiln on a daily basis to cone 6 or cone 8 will need to replace elements much more often than the ceramist with daily cone 05 firings.

If a Duncan element fails prematurely, it can usually be attributed to one of the following causes:

Insufficient Oxide Coating on Elements

This is generally the result of failing to do the initial cone 05 break-in firing that allows the protective alumina coating to form on new elements. Many new kiln owners, not understanding the importance of a proper break-in process and eager to fire their pieces, do their first firing with a load of ware.

Glaze or Kiln Wash on Elements

If even a small spot of glaze or kiln wash touches an element, it will destroy the oxide coating at its point of contact and ruin the element. Glaze and kiln wash on the wall brick can "creep" to a nearby element quite easily during firing and cause failure.

Reduction Firings

An electric kiln is not recommended for reduction firings. As previously mentioned, the protective coating of alumina on the elements is essential for long element life; a reducing atmosphere would cause the coating to be destroyed, thus greatly decreasing element life. While the coating may be restored if an oxidation firing (the standard cone 04-05 bisque firing) is done between reduction firings, it depletes the aluminum content of the element and greatly reduces its life.

Element Replacement

1. *Unplug kiln before beginning any repair.*
2. Remove control panel.
3. Locate damage with multimeter (see Figure 23).
4. Loosen and remove appropriate connector assemblies.
 - a. Use screwdriver and 3/8" hex nut driver or small crescent wrench.
 - b. It is not necessary to disassemble connector.

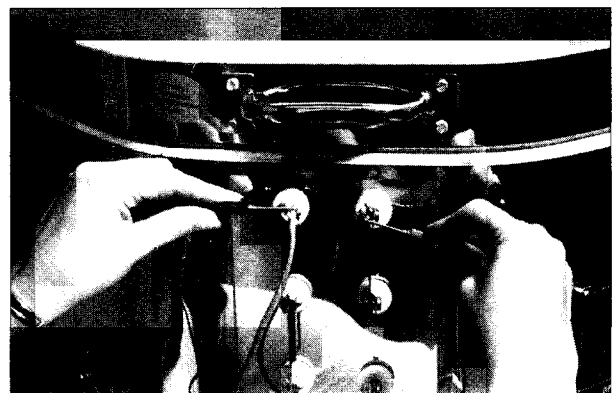

Figure 23

5. Compress each element end with a pair of pliers or cut them off and remove insulators.
6. Use needle-nose pliers to remove old element.
 - a. Carefully pull both ends of element out of terminal brick.
 - b. Gently lift element up and out of groove and free of element slot.
 - c. Do not leave any pieces of old element in groove.
7. Install new element.
 - a. Insert one end of new element through terminal brick. Use needle-nose pliers to help push it through.
 - b. Feed element into slot.
 - 1.) Make sure each performed bend fits snugly into a corner with no tension on groove's lip.
 - 2.) If necessary, compress element as you work around kiln.
 - c. Before feeding element into last two bricks, insert loose end through terminal brick.
 - d. Use a table knife or closed needle-nose pliers to gently press element down into groove (see Figure 24).
 - 1.) Work systematically around kiln, pressing element down every two or three inches.
 - 2.) Be especially careful at corners as bricks chip easily.

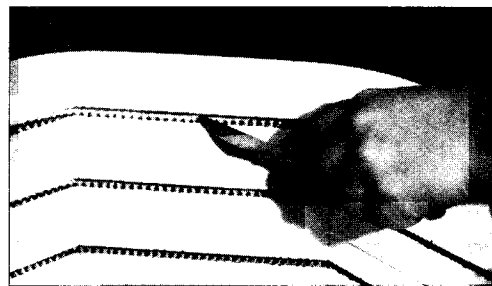

Figure 24

8. Replace insulators.
9. Cut loop off element and spread wires with pliers.
10. Replace connectors (U-terminal or bus bar) onto element.
 - a. Slip element ends between terminal clamp and U-terminal or bus bar, so clamp's curved edges form vise around element.
 - b. Since holes in bus bar and U-terminal are not centered, place widest part toward insulators.
11. Firmly tighten connections (the tighter, the better) (see Figure 25).
 - a. Insulators should be snug against heat shield.
 - b. Element ends should be pulled toward you to take up any slack.



Figure 25

12. Cut off excess element wire close to connectors (see Figure 26).
13. Connect wires from elements to switches, and reposition control panel on kiln.
14. Test kiln with multimeter for electrical soundness.
15. Vacuum kiln, removing all brick chips lodged in element groove.
16. Check ASD adjustment.
17. Test-fire empty kiln (except for three evenly spaced shelves with witness cones on each) to cone 05 to:
 - a. Allow protective oxide coating to form on new elements.
 - b. Check for evenness of firing, so adjustment of heat settings can be made if necessary.

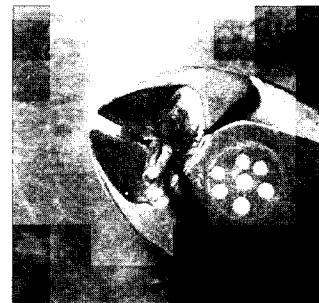

Figure 26

Insulators

Insulators prevent contact between the current-carrying element and the heat shield. Their flanged design permits them to fit snugly over the holes in the heat shield, thereby preventing heat from flowing directly into the control panel, as well as eliminating the possibility of a short (see Figure 27). It is important that the insulator's flange fits tightly against the heat shield to protect the shield's insulation capability.

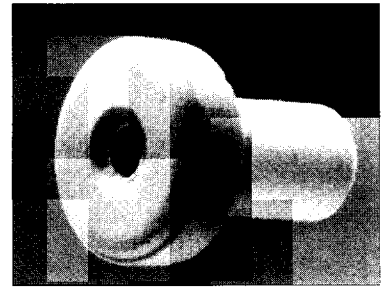

Figure 27

When replacing an insulator, element or any part of a connector assembly, carefully inspect all the other components. The condition that caused one component to fail can affect the others.

It is very uncommon for an insulator to crack, but in the event one does, it should be replaced immediately.

Insulator Replacement

1. *Unplug kiln before beginning any repair.*
2. Remove control panel.
3. Loosen and remove appropriate connector assembly.
 - a. Use screwdriver and $\frac{3}{8}$ " hex nut driver or small crescent wrench.
 - b. It is not necessary to disassemble connector.
4. When replacing an insulator:
 - a. Compress element end with a pair of pliers and twist off damaged insulator. Elements are brittle after firing and will break easily. Use care, even when working with element ends.
 - b. Twist on new insulator, then spread element ends with pliers, as shown (see Figure 28).
5. When replacing bus bar or U-terminal:
 - a. Loosely assemble new unit, as shown (see Figure 29).
 - b. Use connecting wire from old U-terminal assembly, if it's not damaged.
6. Place bus bar or U-terminal assembly onto element.
 - a. Slip element ends between terminal clamp and U-terminal or bus bar so clamp's curved edges form a vise around the element (see Figure 30).
 - b. Since holes in the U-terminals and bus bars are not centered, place widest part toward insulator.

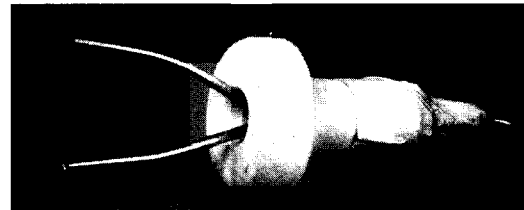

Figure 28



Figure 29

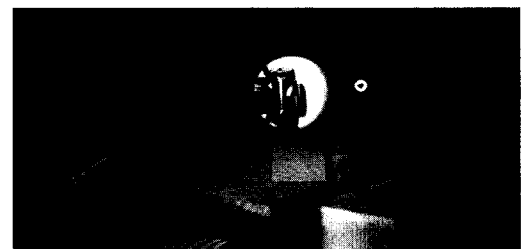

Figure 30

7. Firmly tighten connection (the tighter, the better).
 - a. Insulator should be snug against heat shield.
 - b. Element end should be pulled toward you to take up any slack.
8. Cut off any excess element wire close to connectors.
9. Connect wires from elements to switches, and reposition control panel on kiln.
10. Test kiln with multimeter for electrical soundness.
11. Check ASD adjustment before test-firing kiln.

Element Staples

A brick so badly damaged that it can't support an element is almost impossible to repair. Often brick replacement can be postponed by fastening the element to the brick with Duncan Element Staples (see Figure 31). Both elements and element staples are made of the same resistance wire. Do not use staples or pins of any other material as they will damage the elements.

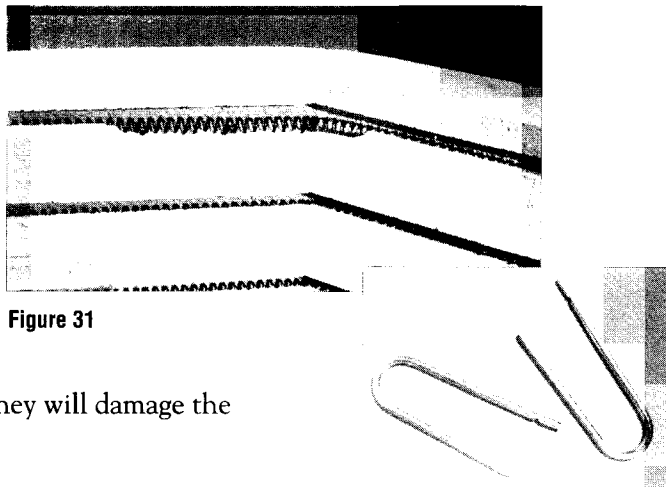

Figure 31

Once an element is fired, it becomes extremely brittle when cool. If an element that has been fired sags out of the brick groove, do the following:

1. Heat element to soften it.
 - a. With lid open, turn appropriate switch to HI-FIRE until elements glow dull red, then turn kiln off and unplug it; OR
 - b. Unplug kiln and, with a propane torch, heat portion of element that will be disturbed.
2. Insert element staples.
 - a. Use needle-nose pliers to insert staple every few inches to secure element to kiln brick.
 - b. Be sure element wire is actually caught between two prongs of the staple.
 - c. Do not allow staple to penetrate through brick and touch kiln case as this could cause a short circuit.

An element that has never been fired is quite flexible and heating to soften is not necessary. Merely insert a staple every few inches as outlined above.

Testing Procedures

The first thing to do before making any tests is to make sure your multimeter or element tester is operating correctly. The tests listed are for measuring resistance (ohms) and for ascertaining whether there's continuity in the unit being tested.

Testing Elements

1. *Unplug kiln before beginning any repair.*
2. Remove control panel (see Figure 32).
3. Using multimeter:
 - a. Set multimeter for ohm-scale reading.
 - b. Test each element within bank.
 - 1.) Place test probes on each element end where it joins connector (U-terminal or bus bar).
 - 2.) Compare ohm reading with chart to establish correct resistance for your particular model's elements.
 - a) If multimeter's needle does not move, element is broken.
 - b) If ohms are much higher than they should be, element is worn out.
 - c) If ohms are much lower than they should be, there is a short circuit to be corrected.
 - d) If all readings are okay, problem may be a switch, connector or connecting wire.

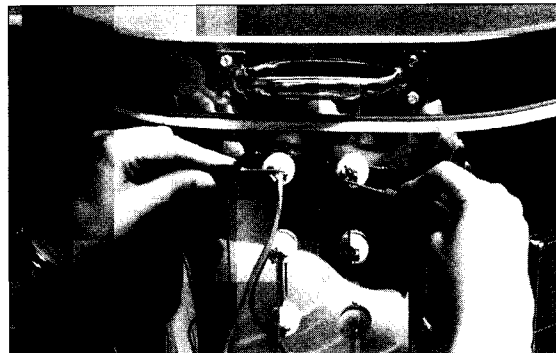

Figure 32

Testing Switches

1. *Unplug kiln.*
2. Remove control panel (see Figure 32).
3. Disconnect all wires from switch.
4. Turn off switch.
5. Prepare troubleshooting equipment for use.
 - a. Set multimeter for ohm-scale reading (see page 31).
6. Check each circuit of switch (see Figure 33) by :
 - a. Placing test probes on switch tabs H1 and L1.
 - b. Placing test probes on switch tabs H2 and L2.
7. Switch is good if:
 - a. Troubleshooting equipment indicates continuity in both circuits, shown when:
 - 1.) Multimeter's needle swings to zero ohms at far right.
 - b. Switch is cycling correctly.
8. Switch is defective if, on either circuit:
 - a. Multimeter's needle does not swing to zero ohms at far right.

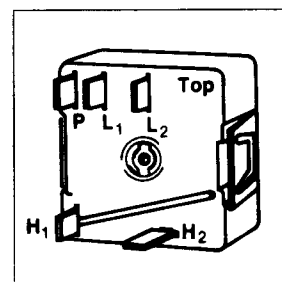

Figure 33

Testing Circuit

A circuit is the path or paths through which electric current flows. The path of a circuit is a closed loop. Any circuit that is complete, with no breaks, is called a closed circuit.

A short circuit or “short” is where the normal circuit is bypassed or the current is flowing through the wrong path. This means the current has found a shorter, easier route where it should not flow, or at least not as strongly as it is flowing. A short creates heat which can damage the kiln or its parts, and can sometimes create a fire hazard if the circuit breaker or fuse doesn't operate properly or is too large.

A circuit breaker or fuse is designed to protect the kiln and wiring from extensive short-circuit damage. The fuse or circuit breaker senses an increase in the current and then interrupts the electrical circuit.

Shorts are usually caused by wires, metal parts or any two conductors (through which current is flowing) that touch when they are not supposed to. A short can usually be found visually or with a multimeter or element tester. Potential shorts can be prevented if the wiring within the control panel is checked for frayed and deteriorated wires as recommended (see **Control Panel Removal**, page 33).

An open circuit is one in which the path is interrupted or broken, so the current can no longer flow through it. An obvious example would be a broken element: the circuit (path) would be open and the elements would not heat as the current could not flow. A multimeter or element tester can help locate an open circuit. If you have no idea where the problem is, the best way to isolate it is to check the largest circuit your equipment will read (a multimeter can check the resistance of a whole kiln; see **Testing for Continuity**, page 41), then check smaller and smaller portions of the circuit (each section, switch, etc.) until you find the problem. An open circuit is usually the result of a loose or broken connection (or lack of one).

Testing Kiln for Electrical Soundness

The following tests should be done in the interest of consumer safety whenever a repair is made that could affect the kiln's electrical components. To be absolutely sure a kiln is electrically correct, do not omit any of these tests.

Testing Kiln's Grounding

1. *Unplug kiln.*
2. Prepare troubleshooting equipment for use.
 - a. Set multimeter for ohm-scale reading (see page 31).
3. Place test probes on plug's ground blade (round) and kiln case (see Figure 34).
4. Kiln is not grounded properly if multimeter's needle does not swing to zero ohms at far right.



Figure 34

5. To determine why kiln is not grounded:
 - a. Place test probes on plug's ground blade (round) and cord's ground screw on side of control panel (see Figure 35). If multimeter's needle does not swing to zero ohms, cord is not grounded properly and is defective.
 - b. Place test probes on cord's ground screw on side of control panel and kiln case. If multimeter's needle does not swing to zero ohms, make sure there is good contact between:
 - 1.) Control panel standoffs and kiln case.
 - 2.) Cord's grounding screw and control panel by removing control panel and checking that star washer is in place.

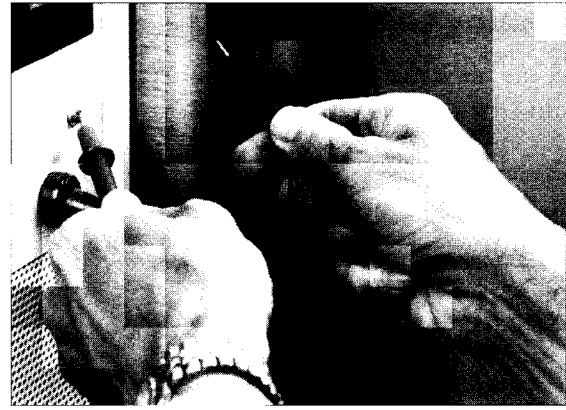

Figure 35

Note: This test only verifies that the kiln is grounded, not the wall receptacle.

Testing for Short Circuits: Hot Wire to Ground

1. *Unplug kiln.*
2. Activate ASD.
3. Turn on switches.
4. Prepare troubleshooting equipment for use.
 - a. Set multimeter for ohm-scale reading (see page 31).
5. Place test probes on plug's ground blade (round) and on one of plug's hot blades, then on other hot blade.
6. A short circuit exists, which must be corrected (see **Testing Circuit**, page 39), if on either circuit:
 - a. Multimeter's needle moves.
 OR
 - b. Element tester lights.

Testing for Short or Open Circuits: Hot Wire to Hot Wire

1. *Unplug kiln.*
2. Activate ASD.
3. Turn on both switches.
4. Set multimeter for ohm-scale reading (see page 31).
5. Place one probe on each hot blade of plug.
6. Compare ohm reading with **Normal Ohms Reading Chart** on page 41 to establish correct resistance for your particular kiln.
 - a. If ohms are considerably less than they should be or zero, there is a short circuit to be corrected (see **Testing Circuit**, page 39).
 - b. If ohms are considerably higher than they should be, there is an open circuit in at least one kiln section.

- c. If multimeter's needle does not move, either:
 - 1.) An open circuit exists (see **Testing Circuit**, page 39)
 - OR
 - 2.) ASD was not activated.
7. If ohm reading does not match **Normal Ohms Reading Chart**, isolate problem (on any Duncan kiln with more than one switch):
 - a. Turn all switches off.
 - b. Turn on one switch at a time.
 - c. Place one probe on each hot blade of plug.
 - d. Compare ohm reading with **Normal Ohms Reading Chart** to establish correct resistance for kiln section.
 - e. If readings do not match, review Step 6 for possible causes.

Normal Ohm Readings Chart

Most multimeters are not accurate enough to give exact readings to a tenth of an ohm. Therefore, the readings you obtain with your particular meter may vary slightly from those listed.

Normal Ohm Reading Chart							
DA Model	Per Element			Per Section			Per Kiln
	TOP	MIDDLE	BOTTOM	TOP	MIDDLE	BOTTOM	
609	13	13	13	6.5	6.5	6.5	6.5
820-2	4.6	—	4.6	18.8	—	18.8	9.4
820-4	4.0	—	4.0	16.3	—	16.3	8.2
1020-2	3.7	—	3.7	15.0	—	15.0	7.5
1020-4	3.2	—	3.2	13.0	—	13.0	6.5
1027-2	15.3	6.0	11.0	15.3	24.0	11.0	*
1029-N	3.7	6.2	11.0	15.0	25.0	11.0	*
1029-2C	3.7	3.7	3.7	15.0	15.0	15.0	5.0
1029-4	3.2	3.2	3.2	13.0	13.0	13.0	4.3

* Per kiln ohms can not be checked on this model.

Testing Safety Timer Motor

Frequently the reason a safety timer (see Figure 36) malfunctions is a loose connection (see **Repairs**, page 45). If this is not the problem, the following tests will help pinpoint the reason.

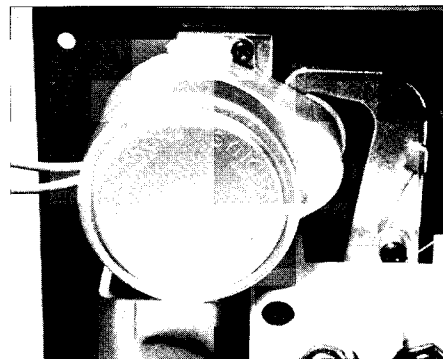

Figure 36

Testing for Continuity

1. *Unplug kiln.*
2. Remove control panel (see **Control Panel Removal**, page 33, for detailed instructions).
3. Set multimeter for ohm-scale reading (see page 31).
4. Turn all switches off.
5. Place test probes on two screws of ASD switch block.
 - a. Meter reading should be between 2,000 and 10,000 ohms.
 - b. If ohms are considerably less, a short circuit exists; replace motor.
 - c. If there is no needle movement, an open circuit exists; replace motor.
6. Reposition control panel on kiln.

Testing Gears

If ohm reading was correct yet timer still does not seem to function, gears may be jammed.

1. Plug kiln in.
2. Activate ASD.
3. Set timer for one hour.
4. Note actual time of day.
5. Check timer one hour later.
 - a. If timer has moved to zero, timer gears are working.
 - b. If timer is still where originally set; gears are jammed; replace motor.

Bus Bars, U-terminals and Insulators

Duncan kilns use both bus bars and U-terminals as element connectors (see Figure 37). Both are made of brass, an excellent conductor, and are plated with nickel to prevent heat corrosion and to prolong life. Bus bars have been used in the electrical field for many years but are somewhat uncommon in the kiln industry. They are good for the Duncan kiln because of the number of elements to be joined, the short distance between elements, their ability to carry current and their rigidity which provides a mechanically secure joint. Both bus bars and U-terminals are available in bulk or as complete connector assemblies. A connector assembly consists of a bus bar or U-terminal, a terminal clamp and hex nut.

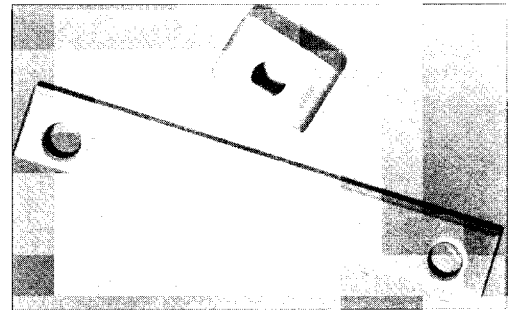

Figure 37

Troubleshooting Infinite Switch (KM 300, KM 301)

On the automatic kilns, the "P" terminal is not used (see Figure 38). If this terminal is used, the switch will malfunction very quickly. Keep this switch clean. It must be in the Off position when the kiln is started. When you rotate the switch, it tends to clean itself; conversely, leaving the switch in one position for a prolonged period of time could cause a malfunction.

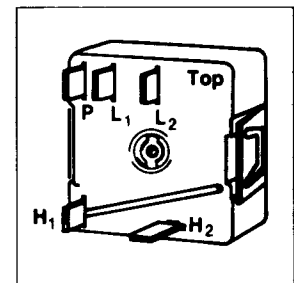

Figure 38

The switch is also susceptible to dust. Clean the switch with air once a month (or more if the environment is very dusty). Do not use spray cleaners like WD-40. Unplug the kiln, remove the panel and blow the switch clean with compressed air.

Switch Replacement

1. *Unplug kiln.*
2. Pull knob off switch (if necessary, pry off with a screwdriver).
3. Remove control panel (see **Control Panel Removal**, page 33).
4. Disconnect all wires attached to the switch being replaced, and note their location on the wires themselves or use a wire schematic.
5. Free switch from control panel by removing pal nut with crescent wrench (see Figure 39).
6. Position new switch in control panel right side up so its nubs fit into locator holes.
7. Screw pal nut onto switch shaft and tighten firmly.
8. Reconnect wires to switch in exact manner as they were previously hooked up (see Figure 40).
9. Connect wires from elements to switches, and reposition control panel on kiln.
10. Replace switch knob. If knob fits loosely, use a screwdriver to slightly spread slot in switch shaft (see Figure 41).
11. Test kiln with multimeter for electrical soundness.
12. Check ASD adjustment before test-firing kiln.

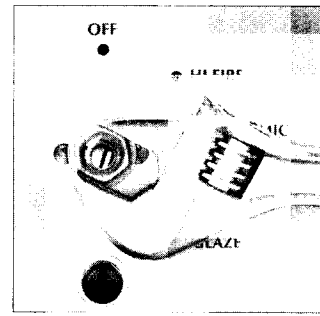

Figure 39

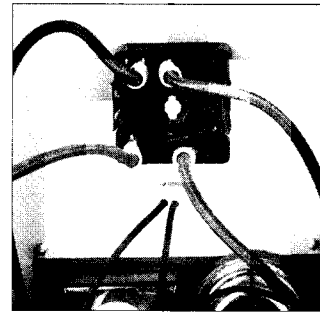

Figure 40

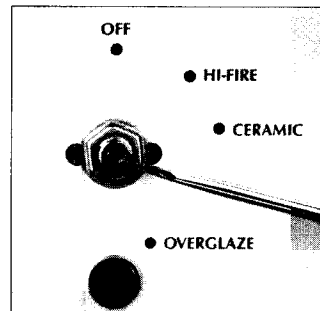

Figure 41

Solid-State Timer and Relay Replacement

4300 Fixed Interval Timer Instructions KM 325

1. *Unplug kiln before beginning any repair.*
2. Remove the screw from the timer to be replaced. Do not remove any electrical connections yet.
3. Remove slip-on terminals one at a time from the old timer and place on the same numbered connection on the new timer (see Figure 42).
4. Use the screw, nut and washer removed in step 2 and fasten the new timer in the control panel.

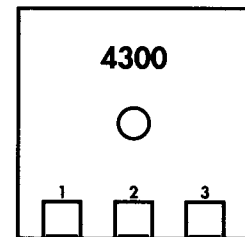

Figure 42

4600 Repeat Cycle Timer Instructions KM 326

1. *Unplug kiln before beginning any repair.*
2. Remove the screw from the timer to be replaced. Do not remove any electrical connections yet.
3. Remove slip-on terminals one at a time from the old timer and place on the same numbered connection on the new timer (see Figure 43).
4. Use the screw, nut and washer removed in step 2 and fasten the new timer in the control panel.

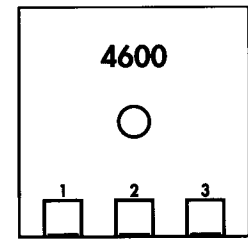

Figure 43

Power Relay (240V) KM 324 Replacement Instructions

1. *Unplug kiln before beginning any repair.*
2. Remove the screws for the power relay to be replaced. Do not remove any electrical connections yet.
3. Remove one slip-on terminal from the old power relay. Connect that terminal to the same post position on the new relay. Continue in this manner until all terminals are reconnected to the new relay (see Figure 44).
4. Use the screws, nuts and washers removed in step 2 and fasten the new power relay in the control panel.

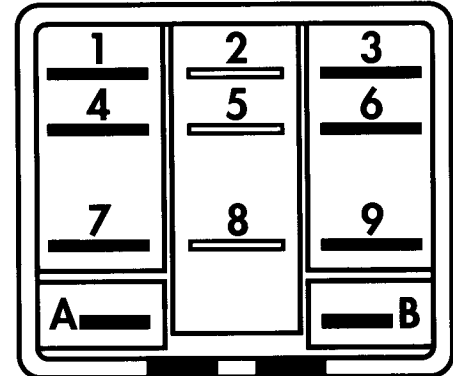

Figure 44

Automatic Shut-Off Device (KM 400)

Every part in an ASD can be replaced individually.

Maintenance Procedures

1. Never use lubricants of any kind.
2. Check ASD adjustment frequently. Heat, corrosion and mechanical wear over time can cause the ASD to slip out of adjustment.
 - a. Turn off all switches.
 - b. Install firing gauge.
 - c. Check position of trigger.
 - 1.) Raise weight up against guide plate, then slowly swing it forward; trigger should just clear tip of claw.
 - 2.) Setscrew in front of weight may be loosened to raise or lower trigger; retighten firmly after adjustment.

- d. Check travel of sensing rod.
 - 1.) Remove firing gauge.
 - 2.) Hold small mirror inside kiln so you can see path of sensing rod.
 - 3.) Press down on claw and check movement of rod with tube cavity; it should not touch sides at any point.
 - 4.) Center sensing rod by loosening guide plate screws and moving guide plate to right or left; retighten screw firmly.
3. Pull sensing rod out of tube and check its appearance frequently. Replace a rod displaying any of the following conditions since they could cause a kiln to underfire or overfire:
 - a. Deterioration of end of rod extending into kiln.
 - b. Bent or warped sensing rod.
 - c. Rod accumulating a buildup of rust at pivot point about 2 $\frac{1}{8}$ inches from claw end of rod.
4. Check appearance of cone supports.
 - a. Deteriorated or warped cone supports should be replaced as they can cause a kiln to underfire or overfire even when all other adjustments are correct.
 - b. A buildup of kiln wash on cone supports, or no kiln wash at all, can cause an ASD to overfire. Generally, kiln wash can be scraped off quite easily; but, if nonremovable materials accumulate, replace the cone supports.

Repairs

The most common ASD repairs will be replacement of the sensing rod or tube assembly. Complete instructions for each of these operations are given in this section. Other mechanical malfunctions can usually be diagnosed by following the appropriate ASD diagram.

Occasionally, a safety timer may not operate. This is usually the result of a loose lead wire, a malfunction or jammed gears in the motor. If you experience such a problem, first be certain it is not the result of a loose wire. Make sure the ends of the wires coming from the timer motor are not loose or disconnected, and that the ends connected to the ASD are held tightly. If all connections are secure, test timer motor following instructions.

Sensing Rod Replacement

1. *Unplug kiln.*
2. Remove old sensing rod.
 - a. Remove screws holding guide plate.
 - b. If rod has not been distorted:
 - 1.) Withdraw rod from tube with guide plate and claw attached.
 - 2.) Remove claw and guide plate from rod.
 - c. If rod has been distorted:
 - 1.) Unscrew claw setscrew.
 - 2.) Remove claw and guide plate from rod.
 - 3.) Withdraw rod from inside of kiln.

3. Install new sensing rod.
 - a. Make sure inside of tube is clean before installing new rod.
 - b. Slide claw onto new rod and tighten claw setscrew.
 - c. If claw has slipped out of guide plate:
 - 1.) Insert rod and claw into top of guide plate slot from front.
 - 2.) With a claw peg in front of guide plate and one behind it, lower claw halfway down slot.
 - d. Holding assembly (guide plate, claw and sensing rod) as shown (see Figure 45), slide sensing rod into tube.
 - e. Position guide plate on front plate and replace screws. Claw is now free to move up and down but is prevented from moving in and out by the pegs.
4. End of sensing rod should be even with ends of cone supports. If adjustment is necessary, loosen setscrew in claw, then retighten firmly.
5. Check ASD adjustment.

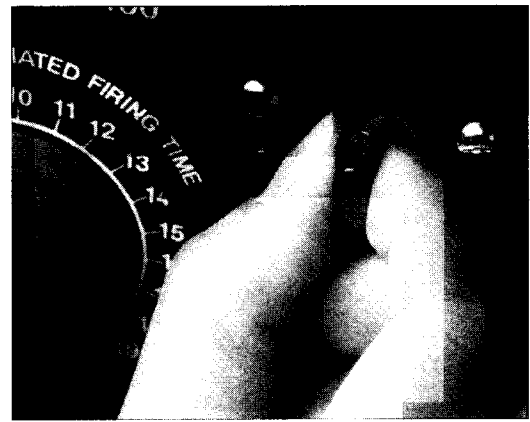

Figure 45

Tube Assembly Replacement

1. *Unplug kiln.*
2. Remove control panel.
3. Remove tube assembly.
 - a. Remove screws holding guide plate.
 - b. Unscrew claw setscrew.
 - c. Remove claw and guide plate from rod.
 - d. Free tube from front plate by removing flat-headed screws located behind guide plate.
4. Attach new tube assembly, positioning it so cone support slots point down (see Figure 46).
5. Slip sensing rod out of tube assembly.
6. Slide claw onto rod and tighten claw setscrew.
7. If claw has slipped out of guide plate:
 - a. Insert claw into top of guide plate slot from front.
 - b. With a claw peg in front of guide plate and one behind it, lower claw halfway down slot.
8. Holding assembly (guide plate, claw and sensing rod), slide sensing rod into tube.
9. Position guide plate on front and replace screws.
10. End of sensing rod should be even with ends of cone supports. If adjustment is necessary, loosen setscrews; retighten firmly.
11. Connect wires from elements to switches, and reposition control panel on kiln.
12. Test kiln with multimeter for electrical soundness.
13. Check ASD adjustment before doing a cone 020 test-firing.

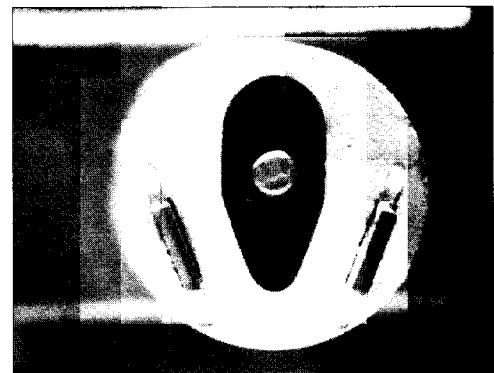

Figure 46

Brick Replacement

Insulating bricks are designed specifically for heat retention. They are made from refractory fireclays and kaolins. These clays are mixed with wood fragments and water to form a heavy slip that is dried before firing. When this mixture is fired, the wood burns out, leaving air pockets to form a light, porous brick with high insulating properties and excellent resistance to heat.

Cracks will form in a kiln's brickwork after firing (particularly in the floor) but are nothing to be concerned about as they serve as expansion joints, opening and closing as the kiln is heated and cooled. Repeated heating and cooling over a very long period of time will eventually cause the bricks to lose their strength and crumble from fatigue. Nevertheless, few kilns used by ceramic hobbyists ever reach this point.

Wall Brick

When used for kiln walls, insulating bricks are not cemented together. The bricks are shaped so that they fit together snugly and are held in position by the kiln case. Replacement bricks are sized and shaped to fit a particular kiln model and are not interchangeable. Each brick has a different end-bevel, depending on the size of the model. Replacements are available for any special brick you need, such as terminal, ASD, peephole, etc. Grooved brick is the most common type (see Figure 47).

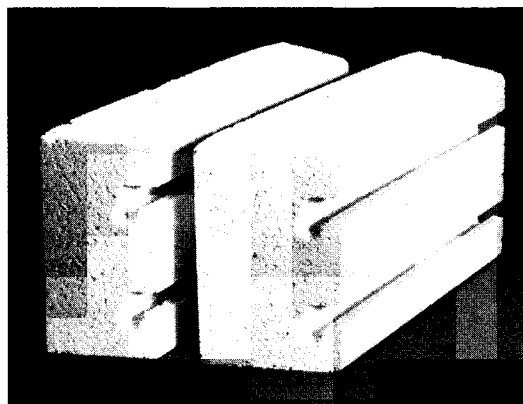

Figure 47

The Duncan brick groove is designed to hold the element firmly in place, eliminating the need for pinning yet ensuring heat radiation into the interior of the kiln—while leaving enough room beyond the coil for easy replacement.

Wall brick should only be replaced when it is too chipped to provide insulation or when it can no longer hold the elements in the grooves. Pinning elements into the grooves with Duncan Element Staples will sometimes enable brick replacement to be postponed until the elements also need replacing (see Figure 48).

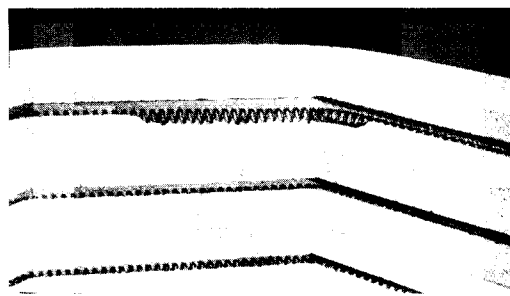

Figure 48

Generally, attempts to patch wall bricks are not advisable, for they usually cause more damage than they correct. It is almost impossible to use a refractory cement to patch the lip of a grooved brick without contaminating an element.

Whenever glaze gets on a brick, it should be dug out with a screwdriver or knife prior to the next firing, otherwise it will remelt and spread, eventually coming into contact with an element and causing it to fail.

Wall Brick Replacement

1. Remove lid by removing hinge and lid-brace mounting or chain mounting from kiln case.
2. Free elements from bricks to be replaced.
 - a. Heat elements to soften them.
 - 1.) With lid open, turn appropriate switch to HI-FIRE until elements glow dull red, then turn kiln off and unplug it;
 - OR
 - 2.) Unplug kiln and, with a propane torch, heat the portion of the elements that will be disturbed.
- b. Use needle-nose pliers to remove elements (see Figure 49).
 - 1.) Lift hot elements up and out of grooves very gently.
 - 2.) Pull them sufficiently free of element slots to allow removal of bricks.
3. Loosen case clamps and remove only as many screws (handle, lid-brace mounting, etc.) from kiln case as necessary to free bricks to be removed.
4. Remove all bricks carefully.
5. Insert replacement bricks, plus any others that have been removed, with element groove down.
6. Tighten case clamps and align peepholes, ASD tube hole and holes in base plate with case. If new peephole brick does not line up right, it can be sanded to the necessary shape.
7. Replace all parts that were removed.
8. Reheat elements.
 - a. Use a propane torch;
 - OR
 - b. Plug in kiln and turn it on.
 - 1.) Loose elements must not touch each other.
 - 2.) Unplug kiln after heating.
9. Use closed needle-nose pliers or table knife to carefully push elements into element slots and down into grooves (see Figure 50).
10. If top bricks are uneven, use sanding block to conform adjoining surfaces (see Figure 51).
11. Test kiln with multimeter for electrical soundness.
12. Vacuum kiln, removing all dust and brick chips.
13. Check ASD adjustment before test-firing kiln.

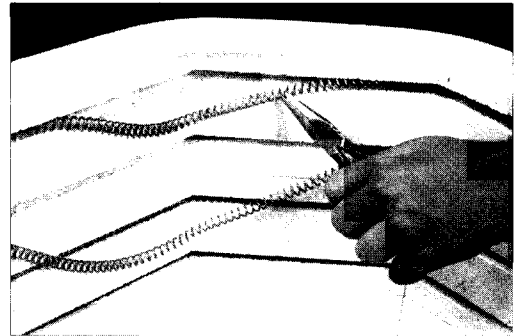

Figure 49

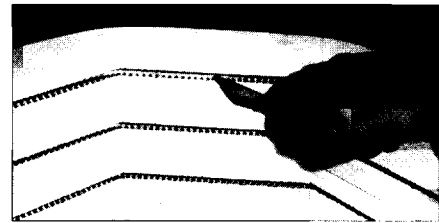

Figure 50



Figure 51

Kiln Bottom

A protective coat of kiln wash should be present on the brick kiln floor at all times. If glaze drips onto the kiln floor, it should be dug out with a knife or screwdriver prior to the next firing and a fresh coat of kiln wash applied. If this process leaves holes in the floor that might affect the stability of the shelves, pack the holes with Duncan Kiln Cement and Sealer or with Duncan Kiln Wash mixed to the consistency of paste. Scrape smooth and allow to dry completely before firing.

A kiln bottom should not be replaced strictly for cosmetic reasons. Fine cracks in the floor do not affect the kiln's firing ability, they merely serve as expansion joints. An irregular floor is no problem as long as a shelf can be stabilized on it; moreover, ware is rarely placed directly on the kiln floor.

A damaged bottom can normally be replaced with ease by following Bottom Replacement Method #1 below. Occasionally, however, a kiln bottom is so badly cracked and crumbled that turning the kiln upside down could cause the floor to fall apart and damage the underside of the lid. When this risk exists, replace the kiln bottom by using Method #2 below.

Bottom Replacement, Method #1: Kiln Upside Down

1. *Unplug kiln.*
2. Place pad of newspapers on floor to prevent scarring top of lid.
3. Remove cone supports from ASD tube.
4. Carefully turn kiln upside down, holding lid closed.
5. Mark case and base plate with a crayon or grease pencil, indicating position of base plate (see Figure 52).
6. Remove screws that hold base plate in position.
7. Loosen case clamps near bottom of kiln and pry off base plate with screwdriver.
8. Loosen all case clamps and pull out floor.
9. Vacuum top of wall bricks, after floor is removed, to eliminate any brick dust on surface.
10. Position new floor, or other side of old floor, on wall brick.
11. Replace base plate, aligning marks and screw holes in case with those in base plate.
12. Install one screw in base plate opposite case clamps.
13. Tighten case clamps, lining up all screw holes, then replace all screws.
14. Turn kiln right side up and place it on stand.
15. Test kiln with multimeter for electrical soundness (see **Testing Kiln for Electrical Soundness**, page 39).
16. Vacuum kiln, removing all brick dust.
17. Check ASD adjustment (see **Maintenance Procedures**, page 44) before test-firing kiln.



Figure 52

Bottom Replacement, Method #2: Kiln in Upright Position

1. *Unplug kiln.*
2. If kiln has collar, remove collar and lid.
 - a. Remove screws on each hinge that connect collar to kiln.
 - b. Lift collar off kiln; set it aside carefully so hinges will not be damaged.
3. If kiln does not have collar, remove lid.
 - a. Disassemble hinge pivot points and one arm of lid brace.
 - b. Remove lid; set it on its edge or upside down to prevent damaging its hardware.
4. Mark case and base plate with a crayon or grease pencil, indicating position of base plate.
5. Remove kiln from stand and place on floor.
6. Remove screws that hold base plate in position.

7. Slightly loosen bottom case clamp only.
8. Stand inside kiln and pull up on case handles to free kiln from bottom (see Figure 53).
9. Step off kiln bottom and carefully set kiln on floor; kiln will be resting on its case.
10. Transfer base plate to new bottom.
11. Slide kiln down onto new bottom, aligning marks and screw holes in case with those in base plate.
12. Install one screw in base plate opposite case clamps.
13. Tighten case clamps, lining up all screw holes, then replace all screws.
14. Replace lid (or collar) and place kiln on stand.
15. Test kiln with multimeter for electrical soundness (see **Testing Kiln for Electrical Soundness**, page 39).
16. Vacuum kiln, removing all brick dust.
17. Check ASD adjustment (see **Maintenance Procedures**, page 44) before test-firing kiln.

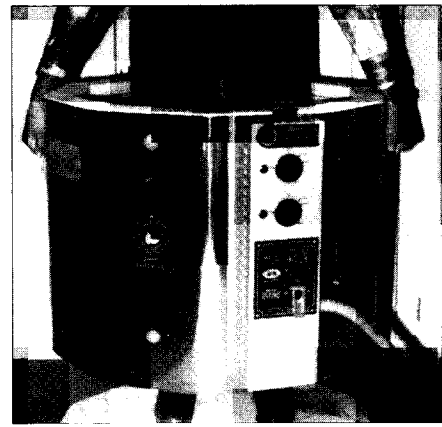

Figure 53

Kiln Lid

Minor damage to a kiln's lid will not affect its performance. However, if the lid coating is chipped or gouged, leaving a crumbled area, the condition will get worse if the crumbling is not stopped. Simply smooth the area with sandpaper, vacuum up the dust and brush on a thin coat of Duncan Kiln Cement and Sealer. Never use kiln wash on the underside of the kiln lid. If lid replacement is necessary, installing a new one is quite simple. Periodically check the lid band for tightness and make any necessary adjustments.

Lid Replacement

1. *Unplug kiln.*
2. Remove lid-brace mounting plate from old lid.
3. Remove all screws from lid hinges.
4. Remove old lid and place new lid on kiln.
5. Position lid so corners are lined up and handle is centered over control panel.
6. Attach hinges to lid.
 - a. Use prepunched locator holes in band for two top holes in each hinge.
 - b. Keep top edge of hinge parallel with band.
 - c. Use center punch or sharp nail to start holes in band for remaining screws.
7. Attach lid-brace mounting plate to lid, using prepunched locator holes in band as guide.
8. Vacuum kiln, removing all brick dust.

Hinges

Both the kiln and its lid expand with heat. Therefore, a Duncan kiln has self-leveling hinges, designed so that the pivot not only rotates but also moves up and down vertically. This allows the lid to float and level itself, keeping undue stress from being placed on the back bricks. Otherwise, at high temperatures, there would be a gap at the kiln's front between the lid and top brick, resulting in heat loss and damage to both the lid and the bricks where the hinges are attached. If a kiln shows signs of gaping at the front during firing, loosen the hinge pivot slightly.

Brace

Refer to the specific instructions that are packaged with a new lid brace.

19

Two-Year Limited Kiln Warranty

Duncan Enterprises ("Duncan") hereby warrants all ceramic kilns manufactured by Duncan, together with all component parts, against defects resulting from faulty workmanship or materials for a period of two (2) years from the date of purchase, subject to the terms and conditions set out below.

1. *Parties Entitled to Benefits Under this Warranty*

Only the original purchaser of a Duncan kiln can claim benefits under this Warranty. For purposes of convenience, this Warranty refers to the original purchaser of a kiln as "you" and all references to "you" or "your" in this warranty are to the original purchaser only.

2. *Your Responsibilities*

In order to take advantage of benefits under this Warranty, you must do the following:

- a. If Duncan has a Distributor in your area, you must take these steps: (1) Upon request, offer proof of purchase of the kiln, including the date on which you made the purchase (your invoice will usually suffice); (2) Notify the distributor in your area of any defect by letter or telephone within a reasonable time after you discover the defect, but in no event more than fourteen (14) days after the discovery. (If you do not know the name of the Duncan Distributor in your area, call Duncan's Customer Service Department at (800) 237-2642 or (209) 291-4444, or write to 5673 East Shields Avenue, Fresno, California 93727); (3) Deliver or ship the kiln to the distributor's place of business for repair or replacement of defective parts, or replacement of the entire kiln, if necessary. You must pay the cost of delivering or shipping the kiln to the distributor's place of business and the cost of transporting or shipping the repaired kiln or new kiln from the distributor's place of business to your residence or place of business.
- b. If Duncan does not have a Duncan Distributor in your area, you must take these steps: (1) Furnish Duncan's Customer Service Department with proof of purchase of the kiln, including the date on which you made the purchase (again, your invoice will usually suffice); (2) Notify Duncan's Customer Service Department by letter (5673 East Shields Avenue, Fresno, California 93727) or telephone (800) 237-2642 or (209) 291-4444) of any defect within a reasonable time after you discover the defect, but in no event more than fourteen (14) days after discovery; (3) If only a part is defective, send the part, shipping charges prepaid, to Duncan's Customer Service at 5673 East Shields Avenue, Fresno, California 93727. (Note: Since repairs can often be made without shipment of the entire kiln, we suggest you call or write Duncan's Customer Service Department before seeking warranty repairs from Duncan so that our experienced personnel can help you choose the best way to obtain repairs.); (4) If the entire kiln is defective or if repairs cannot be made without access to the kiln, (A) Send the kiln, shipping charges prepaid, to Duncan's Customer Service Department at 5673 East Shields Avenue, Fresno, California 93727; (B) Notify Duncan's Customer Service Department, by letter (5673 East Shields Avenue, Fresno, California 93727) or telephone (800) 237-2642 or (209) 291-4444, of your intent to ship the kiln, no later than the date of actual shipment; and (C) Pay shipping charges for the return of the repaired kiln or the delivery of a new kiln.

3. *Your Duncan Distributor's Responsibilities*

If the kiln or any component part becomes defective within two (2) years after purchase of the kiln and your warranty work is performed by a Duncan Distributor, the distributor will:

- a. Repair or replace, at the distributor's option, any defective part or parts if the kiln can be restored to proper operation by such repair or replacement.

- b. Replace the entire kiln if the kiln cannot be restored to proper operation by the repair or replacement of component parts.

4. *Duncan's Responsibilities*

If the kiln or any component part becomes defective within two (2) years after purchase of the kiln and your warranty work is performed by Duncan's Customer Service Department, Duncan will:

- a. Repair or replace, at Duncan's option, any defective part or parts sent to Duncan's Customer Service Department and send the new or repaired parts to you, shipping charges prepaid.
- b. Repair or replace, at Duncan's option, any kiln sent to Duncan's Customer Service Department and send the new or repaired kiln to you upon your payment of all shipping charges from Duncan's loading dock to your residence or place of business, per invoice from Duncan.

5. *Length of this Warranty*

This Warranty shall expire two (2) years from the date of purchase, and any repair or replacement of kilns or component parts after the initial two (2) year warranty period shall be made at your sole expense and upon such terms as you may arrange with the person or business performing the repair work.

6. *Exclusions and Limitations*

This Warranty does not apply to the kiln or its components if any one or more of the following circumstances shall be present:

- a. The kiln has suffered freight or transit damage (such damage may be the responsibility of the shipper).
- b. The kiln has suffered deterioration because of abuse, improper storage or exposure to the elements.
- c. The kiln has been altered so that it no longer conforms to Duncan factory specifications.
- d. The serial number or the face of the kiln has been altered, obliterated or otherwise rendered illegible.
- e. The kiln has suffered damage from overfiring (i.e., exceeding the melting temperature of the object or material being fired), regardless of the cause of such overfiring.
- f. The temperature of the kiln has been allowed to exceed the cone or temperature shown on the rating plate.
- g. The kiln has been operated on a voltage other than the voltage specified on the rating plate.
- h. The kiln has been connected to a source of electric power in a way not specified or permitted in the instructions accompanying the kiln.
- i. The kiln has been utilized for any purpose other than the firing of ceramic materials.
- j. The kiln has been used for reduction or salt firing.
- k. The object or material inside the kiln or the kiln furniture has been damaged by overfiring.

This Warranty is in lieu of all other warranties, whether express or implied, except insofar as such additional warranties may be required or imposed by law. Neither Duncan nor any Duncan Distributor makes any warranty of merchantability or fitness for any particular purpose as to Duncan kilns. Under no circumstances shall Duncan, its agents, its servants or its employees be liable for any incidental or consequential damages resulting from the use of its kiln products or from defects in workmanship or materials in its kiln products. Under no circumstances shall any Duncan Distributor, or the Distributor's agents, servants or employees, be liable for any incidental or consequential damages resulting from the use of Duncan kiln products or from defects in workmanship or materials in any Duncan kiln products.

Some states do not allow the exclusion of implied warranties or limitations on how long implied warranties may last, so the above limitation or exclusion may not apply to you insofar as it concerns implied warranties. Some states do not allow the exclusion or limitation of incidental or consequential damages, so the above limitation or exclusion may not apply to you insofar as it concerns incidental or consequential damages. This Warranty gives you specific legal rights, and you may also have other rights, which may vary from state to state.

No employee or agent of Duncan is authorized to alter the terms of this Warranty, nor is any Duncan Distributor authorized to alter the terms of this Warranty. This Warranty is made exclusively by Duncan, and you are not authorized to claim benefits hereunder from any person or entity except a Duncan Distributor.

DUNCAN ENTERPRISES

Customer Service Department
5673 East Shields Avenue
Fresno, California 93727
Phone: (209) 291-4444
FAX: (209) 291-9444

Choosing Your Cone

Use the following chart as a general guide to selecting the right cone, but always check the label on the jar for specific directions. There are exceptions to these guidelines.

Type of Firing	Shelf Cone Desired	Orton Pyro-Bar Type Cone for Kiln-sitter	Orton Pyramid Type Cone for Kiln-sitter	Large Witness Cones
BISQUE				
Stains, acrylics	06-04	06-04	05-1/2-03	06-04
Crackletone Glazes	06	06	05-1/2	06
Stains that have glazed areas	04	04	03	04
General-purpose ware	04	04	03	04
Duncan Red-Strokes	03	03	02	03
Porcelain	6	7	7	6
Stoneware	6	7	7	6
GLAZE				
Luster (Mother-of-Pearl)	02	020	020	020
Metallic overglazes	019	019	019	019
China paints	019	019	019	019
Decals	01	018	018	018
Hobby ceramics glazes*	06	06	05-1/2	06
Porcelain or stoneware glazes	6	7	7	6

* When properly fired to witness cone 06, Duncan glazes labeled as dinnerware comply with the Food and Drug Administration's safety requirements concerning lead and cadmium release.

Be aware that the lower the cone number, the cooler the firing and vice versa. Thus, numbers prefaced by zero (cone 05, for example) are cooler than numbers which stand alone (such as cone 5). Heat increases as the cone numbers increase (cone 06 is cooler than cone 05, and cone 6 is hotter than cone 5). See the **Conversion Table for Pyrometric Cones** on page 56.

Note: These are general guidelines. Always check the specific product label for the recommended witness cone.

Conversion Table for Pyrometric Cones

C°	F°	Orton Cones	British Cones	Seger Cones
600	1112	—	022	022
605	1121	022	—	—
615	1139	021	—	—
650	1202	020	021	021
660	1220	019	—	—
670	1238	—	020	020
690	1274	—	019	019
710	1310	—	018	018
720	1328	018	—	—
730	1346	—	017	017
750	1382	—	016	016
770	1418	017	—	—
790	1454	—	015	015a
795	1463	016	—	—
805	1481	015	—	—
815	1499	—	014	014a
830	1526	014	—	—
835	1535	—	013	013a
855	1571	—	012	012a
860	1580	013	—	—
875	1607	012	—	—
880	1616	—	011	011a
895	1643	—	—	—
900	1652	011	010	010a
905	1661	010	—	—
920	1688	—	09	09a
930	1706	09	—	—
940	1724	—	08	08a
950	1742	08	—	—
960	1760	—	07	07a
980	1796	—	06	06a
985	1805	07	—	—
1000	1832	06	05	05a
1020	1868	05½	04	04a
1040	1904	05	03	03a
1060	1940	04	02	02a
1080	1976	—	01	01a
1100	2012	—	1	1a
1115	2039	03	—	—
1120	2048	—	2	2a
1125	2057	02	—	—
1140	2084	—	3	3a
1145	2093	01	—	—
1160	2120	1	4	4a
1165	2129	2	—	—
1170	2138	3	—	—
1180	2156	—	5	5a
1190	2174	4	—	—
1200	2192	—	6	6a
1205	2201	5	—	—
1230	2246	6	7	7
1250	2282	7	8	8
1260	2300	8	—	—

Duncan Kiln Specifications

MODEL NUMBER	VOLTAGE*	FIRING CHAMBER		CUBIC FEET	OUTSIDE DIMENSIONS			MAXIMUM TEMPERATURE		ELECTRICAL REQUIREMENTS*			KILN SHIPPING WEIGHT		
		WIDTH	DEPTH		WIDTH	DEPTH	HEIGHT	CONE	°F	AMPS	WATTS	COPPER WIRE SIZE		CIRCUIT/FUSE SIZE	KILOWATT HRS. PER FIRING**
THE HOBBYIST Model 609															
DB 609	120	11"	9"	.56	19"	22.5"	14.5"	8	2300	17	2040	12	20	4.75	72 lbs.
THE TEACHER Model 820															
<i>All-Brick Automatic plus Override Switch for Manual Firing</i>															
DA 820-2	240	17.5"	19.75"	2.9	25"	28"	25.5"	8	2300	24	5760	10	30	20	145 lbs.
DA 820-4	208	17.5"	19.75"	2.9	25"	28"	25.5"	6	2246	24	4992	10	30	24	145 lbs.
THE STUDIO Model 1020															
<i>All-Brick Automatic plus Override Switch for Manual Firing</i>															
DA 1020-2	240	23.13"	19.75"	5.0	31"	33"	25.5"	8	2300	30	7200	8	40	32	190 lbs.
DA 1020-4	208	23.13"	19.75"	5.0	31"	33"	25.5"	6	2246	30	6240	8	40	34	190 lbs.
THE PRO Model 1029															
<i>All-Brick Automatic plus Override Switch for Manual Firing</i>															
DA 1029N	240	23.13"	28.75"	7.3	31"	33"	34.5"	8	2300	45	10800	6	60	40	240 lbs.
DA 1029-4	208	23.13"	28.75"	7.3	31"	33"	34.5"	6	2246	45	9360	6	60	48	240 lbs.
THE POTTER Model 1027-2															
<i>All-Brick Manual</i>															
DB 1027-2	240	22.13"	26.75"	6.3	31"	33"	33"	11	2417	45	10800	6	60	28	332 lbs.

* All models can be operated on either a single-phase or any two legs of a three-phase circuit.

** Cone 05 firing average.

NEMA configurations

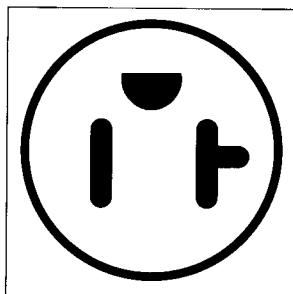

Model 609
5-20R

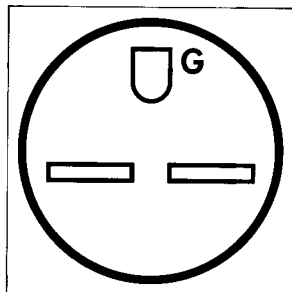

Model 820
6-30R

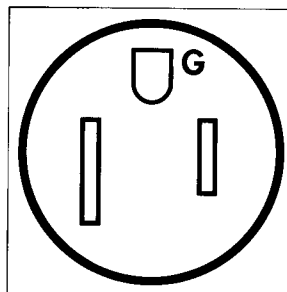











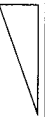

Models 1020/29/27
6-50R

How to Fill Out Your Firing Record

By keeping accurate records, you'll be able to duplicate your successful firings, avoid the unsuccessful ones and repeat any desirable modifications you add to your procedures.

- Column 1)** Be sure to mark the number of the small cone used in the ASD as well as the place where the sensing rod touches it (i.e., if the rod is centered; if the rod is at the thin end).
- Column 2)** Indicate the number of each witness cone you use under the appropriate heading. Remember that the FIRING cone is the most important one, as only this cone can establish that the proper maturity has been attained for the products being fired.
- Column 3)** Record the type of firing (i.e., greenware, porcelain, reds, golds, etc.) and the amount of ware and furniture in the kiln (i.e., full load, 3 shelves, light load, 1 shelf).
- Column 4)** This column will only be used if there is a safety timer on your kiln. Record the number of hours you set the timer. This can be a most important guide if your kiln should overfire or if it should turn off prematurely.
- Column 5)** Record the time you start your firing cycle and each time you turn the switches (if required by your model kiln), as well as the time the ASD shuts the kiln off. Unless you hear the weight of the ASD fall or have a safety timer, however, it is nearly impossible to establish when the kiln turned off.
- Column 6)** Indicate the appearance of each FIRING cone by using the clock system. In other words, compare the position of the tip of the bent cone with the hour hand of an imaginary clock. In the unfired position, a cone is at 12 o'clock. A cone at 3 o'clock is one which has bent over so that its tip is pointing toward 3 on the imaginary clock face. Other cone positions are easily identified by comparing them to a clock face (see Figure 15 on page 11).
- Column 7)** In this column you might record the position of FIRING cones if you had more than three shelves, or make a note about the GUIDE or GUARD cones if appropriate, the appearance of the ware, or any unusual occurrence (i.e., ASD did not trip, power was off, switches left on low 15 minutes longer than normal, etc.).

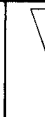
Firing Record

Date	Small Kiln-Sitter Cone		Large Witness Cones			Size & Type of Load	Safety Timer	Time of Day					Total Firing Time		Firing Cone Appearance			Remarks
	Cone Number	Position of Rod	Guide	Firing	Guard			Low	Medium	High	Hi-Fire	Kiln Shuts Off	Hours	Minutes	Top Shelf	Mid Shelf	Bottom Shelf	
																		
																		
																		
																		
																		
																		
																		
																		
																		
																		
																		
																		
																		
																		

Index

Automatic Shut-Off Device (ASD)	5	Kiln Specifications	57
Maintenance	44	Kiln Wash	14
Sensing Rod Replacement	45	Loading the Kiln	15
Tube Assembly Replacement	46	Bisque Firing	16
Bus Bars, U-terminals & Insulators	42	Glaze Firing	16
Cones	11	Overglaze Firing	17
ASD Cones	11	Porcelain	17
Choosing Your Cone	55	Stoneware	17
Conversion Table for Pyrometric Cones	56	Multimeter	30
Witness Cones	11	Ohm-Scale Reading	31
Control Panel	32	Volt-Scale Reading	31
Elements	34	Ohms Readings Chart	41
Replacement	34	Pyrometer	14
Testing Elements	38	Recognizing Firing Faults	24
Element Staples	37	Safety Tips	4
Firing		Solid-State Timer & Relay	43
ASD Test Firing	19	Switches	9
Automatic Mode	21	Replacement	43
Hobbyist Kiln	22	Testing	38
Manual Mode	21	Testing	
Potter Kiln	22	Circuit	39
Firing Record	59	Elements	38
Standard Switch Locations	9	Gears	42
Infinite Switch	42	Kiln's Grounding	39
Insulators	36	Safety Timer Motor	41
Replacement	36	Short Circuits	40
Kiln Bottom Replacement	49	Switches	38
Kiln Lid Replacement	50	Troubleshooting	
Kiln Furniture		Chart	28
Hobbyist Stand	3	Infinite Switch	42
Shelves & Posts	10	Wall Brick	47
Ventilation System	10	Replacement	48
Kiln Parts		Warranty	52
Lid Safety Switch (<i>export models only</i>)	8		
Lid Vent Hole	8		
Lid Vent Prop	8		
Peepholes	7		
Pilot Light	9		
Safety Timer	8		