

What's a Watt?



**Understanding
Basic Electricity for the Paragon Kiln
Maintenance Seminar**

Instructions

To work on Paragon kilns, you must understand basic electricity. “What’s a Watt?” will give you this understanding, even if you know nothing about electricity now. It’s written for the complete beginner who doesn’t know a switch from a socket. Those of you who have electrical experience may find “What’s a Watt?” easy, but we urge you to read it anyway.

Throughout the book are questions to reinforce what you’ve learned. The answer to each question appears next to the following question. Cover the answer by placing a sheet of paper under the question you’re working on, and circle the correct answer or fill in the blank. Then slide the paper down to the next question and check your answer before going further. If your answer was correct, read the next question. If your answer was wrong, go no further until you find out why it was wrong. If needed, re-read the material that pertains to that question. Please don’t look at the answer to a question until you’ve answered it yourself!

The first thing we’ll do at our kiln seminar is test you on basic electricity. We’ll also review it if anyone has any questions.

What's a Watt?

Understanding Basic Electricity for The Paragon Kiln Maintenance Seminar

Most people find electricity hard to understand. It cannot be seen, so it's mysterious. Volts, amps, and ohms are like Greek. But if we compare electricity to something we can see that works like electricity, it's easier to understand. So we'll compare it to water.

The water tanks

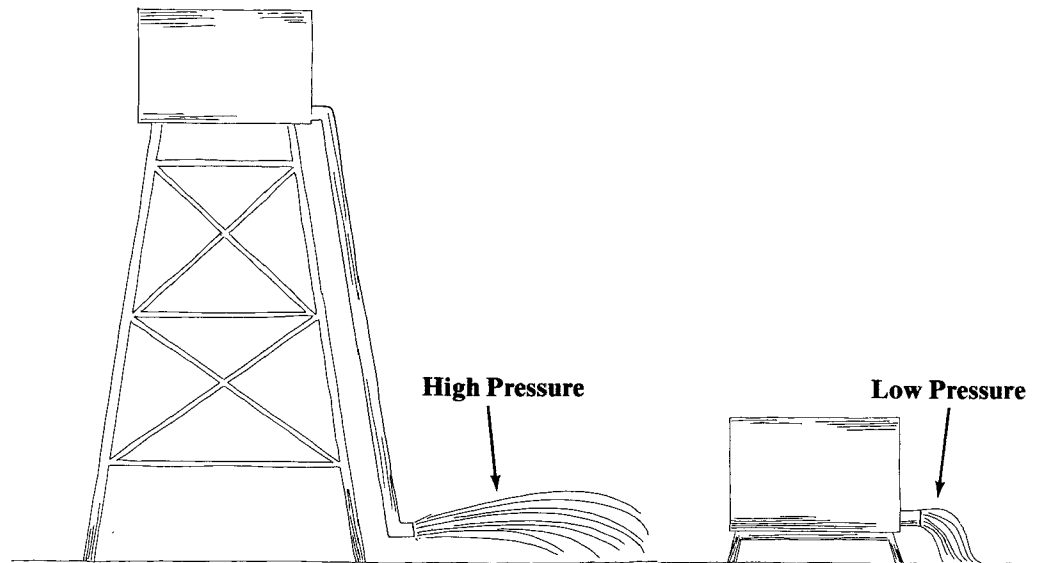

There are two water tanks. One is at ground level, and the other is several hundred feet high. By connecting a pipe of equal size to each tank and letting the water run out, we can see that the high tank has much more water pressure than the low tank. The high tank will be empty much sooner. The higher the water tank, the harder will its water come pounding out of a pipe. Gravity increases water pressure with altitude.

1. The higher the water tank, the (*less, more*) the water pressure.

1. *more*

2. The low tank will be empty (*sooner, later*) than the high tank.

2. *later*

When a paddle wheel is placed in front of the water flowing from each tank, one paddle wheel turns faster than the other. The water from the high tank forces its paddle wheel to spin fast. The water from the low tank is driven by less pressure, so its paddle wheel barely turns.

3. The paddle wheel from the (*high, low*) tank turns faster.

3. *high*

4. The paddle wheel from the low tank turns slower because water is hitting it with (*more, less*) force.

4. *less*

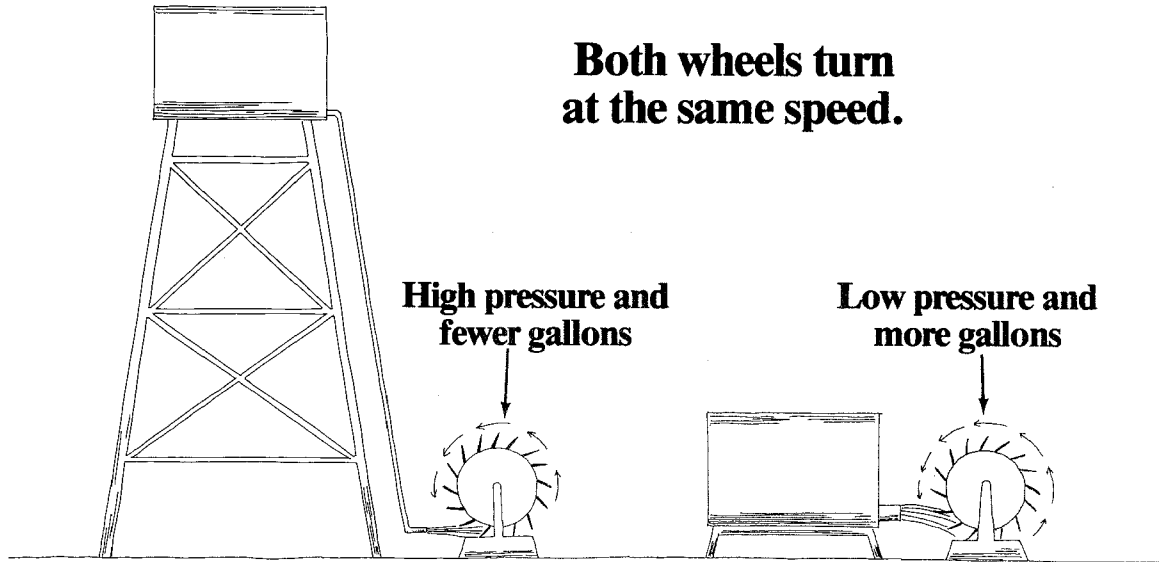

There is a way to make both wheels turn at the same speed. We remove the pipes and replace them with a small diameter pipe and a large diameter pipe. The small pipe is hooked up to the high tank and the large pipe to the low tank.

The small pipe lets only a little water stream out of the high tank, and the big pipe lets lots of water gush out of the low tank. But when the water hits the wheels, both wheels turn at the same speed. The water from each tank is doing the same amount of work, but in different ways. Although the small pipe lets only a little water out of the high tank, that water is under great pressure, so it shoots out in a powerful stream. The big pipe lets lots of water gush out of the low tank, but the water is under low pressure, so it gently flows out. The high tank turns its wheel with high, pounding pressure and *fewer* gallons of water. The low tank turns its wheel with low, gentle pressure and *more* gallons of water.

So water pressure alone or gallons of water alone doesn't measure work performed by water. We have to consider both pressure and gallons.

5. Which tank is the large diameter pipe connected to? (*high tank, low tank*)
6. The small pipe from the high tank (*increases, decreases*) the volume of water that hits the paddle wheel.
7. The low tank uses more (*volume, pressure*) of water to turn its paddle wheel at the same speed as that of the high tank.
8. The high tank uses more (*volume, pressure*) of water to turn its paddle wheel at the same speed as that of the low tank.
9. The small water pipe decreased the water (*volume, pressure*).
10. Fewer gallons flowed from the high water tank because its water flowed through the (*large, small*) pipe.
11. The work performed by water, such as turning a paddle wheel, is determined by water volume and water _____.

5. *low tank*

6. *decreases*

7. *volume*

8. *pressure*

9. *volume*

10. *small*

11. *pressure*

Amps

Electricity works something like the water tanks. So to understand electricity we can replace pipes with wires and water with electrons. The volume of water is measured in gallons. The volume of electricity is measured in amperes (amps). One amp represents a certain number of electrons speeding through a wire during one second. Don't be concerned with how many electrons are in one amp. (It's many, many billions.) Just understand that one amp is a certain number of electrons moving past a point in one second. This is like measuring running water in gallons per second.

12. An amp is comparable to the (*pressure, volume*) of water.

12. *volume*

13. A pipe is to water what (*a switch, a wire*) is to electricity.

13. *a wire*

14. The volume of running water per second is measured in gallons per second. The volume of electrons per second is measured in _____.

14. *amps*

Volts

Water is driven through pipes by water pressure. Electricity is driven through wire by pressure, too. Electrical pressure is called voltage. The electrical equivalent of the low water tank is a 12 volt battery, and the equivalent of the high tank is 120 volt house current.

High water pressure forces water to shoot out of the high tank. Low pressure just gently pushes the water out of the low tank. Voltage is something like that. 120 volts pushes more volume of electricity through a wire than 12 volts.

15. The high tank has (*more, less*) water pressure than the low tank.

15. *more*

16. Water pressure is comparable to (*amps, volts*).

16. *volts*

17. Running water measured in gallons per second is comparable to (*amps, volts*).

17. *amps*

18. A 12 volt battery has (*more, less*) electrical pressure than 120 volt house current.

18. *less*

Ohms

To make the water from the tanks turn 2 wheels at the same speed, we had to use a small pipe to hold back the water from the high tank. Electricity can be held back, too. A small wire will resist electricity like the small water pipe resisted water. Electrical resistance is called ohms. A longer wire has more resistance than a short one; a thin wire has more resistance than a thick one. The higher the number of ohms, the higher the resistance of the wire.

19. Resistance is measured in (*ohms, volts, amps*).

19. *ohms*

20. Electrical pressure is measured in (*ohms, volts, amps*).

20. *volts*

21. The number of electrons flowing through a wire is measured in (*ohms, volts, amps*).

21. *amps*

22. *Volts*

23. *more*

24. *more*

25. *voltage*

22. (*Ohms, Volts, Amps*) is comparable to water pressure.

23. A small wire has (*more, fewer*) ohms than a large wire.

24. A small wire offers (*more, less*) resistance to current flow than a large wire.

25. Adding more water pressure to a water system is like increasing (*amperage, voltage, resistance*) in an electric circuit.

Watts

Water pressure alone or gallons of water alone doesn't measure the work performed by water. Both pressure and gallons have to be considered. Electricity is the same. Voltage alone or amps alone doesn't measure the work performed by electricity. Both electrical "pressure" and electrical "volume" have to be considered. Electrical work is measured by multiplying pressure by volume (volts x amps). This equals watts. For example, 5 amps x 12 volts = 60 watts. Watts is the measure of work done by electricity, because it is the measurement of both volts (pressure) and amps ("gallons").

26. *decreases*

27. *low*

28. *volts*

29. *Volts*

30. *increasing*

31. *amps*

32. *60*

33. *watts*

26. When a wire has high resistance, it (*decreases, increases*) the flow of electrons.

27. When a wire has few ohms, it is of (*high, low*) resistance.

28. Water pressure is similar to (*ohms, amps, volts*).

29. (*Volts, Amps*) push the electrons through the wire.

30. Bending a water hose to lessen the flow of water is like (*decreasing, increasing*) ohms.

31. Watts is calculated by multiplying volts by (*amps, ohms*).

32. 5 amps x 12 volts = (*60, 120, 240*) watts.

33. Electrical work is measured in (*volts, watts, amps*).

Light bulbs instead of paddle wheels

Instead of using water to turn wheels, we'll use electricity to light light bulbs. The high water tank is replaced by 120 volt house current and the low water tank by a 12 volt battery. The pipes are replaced by wire, and the wheels are replaced by light bulbs. The light bulbs will both be the same voltage and wattage: 12 volts and 60 watts.

When the battery is hooked up to one bulb and the house current to the other, the bulbs both glow. The bulb powered by the battery glows normally, but the one powered by 120 volts glows very brightly for a few seconds and then burns out.

34. Why did the 12 volt, 60 watt bulb burn out on the 120 volt circuit?

- a) *Too much voltage.*
- b) *Too much resistance.*
- c) *The wire was too thin.*

34. (a)

35. *paddle wheels*

36. *pipes*

37. *high*

38. *120 v.*

39. *faster*

35. In the comparison given, light bulbs are compared to (*water tanks, paddle wheels*).

36. Wire is compared to (*paddle wheels, pipes*).

37. When the pipes connected to the high and low water tanks were of the same diameter, the paddle wheel from the (*high, low*) tank turned faster.

38. When the light bulbs of the same voltage were connected to 12 and 120 volt power sources, the bulb on the (*12 v., 120 v.*) circuit glowed brightly and burned up.

39. The bulb glowing brighter is like the paddle wheel turning (*faster, slower*).

There is a way to light two 60 watt bulbs from both 12 and 120 volts and get the same light output. We can use the same technique we used to turn the wheels the same speed from different tanks: we vary the amperage, or “gallons” of electricity. We held back the huge flow of water from the high tank with a small pipe. We can hold back the excess flow of amperage from the 120 volt current with a small wire, too. The smaller the wire, the more the resistance, or ohms.

Both bulbs give out the same amount of light.

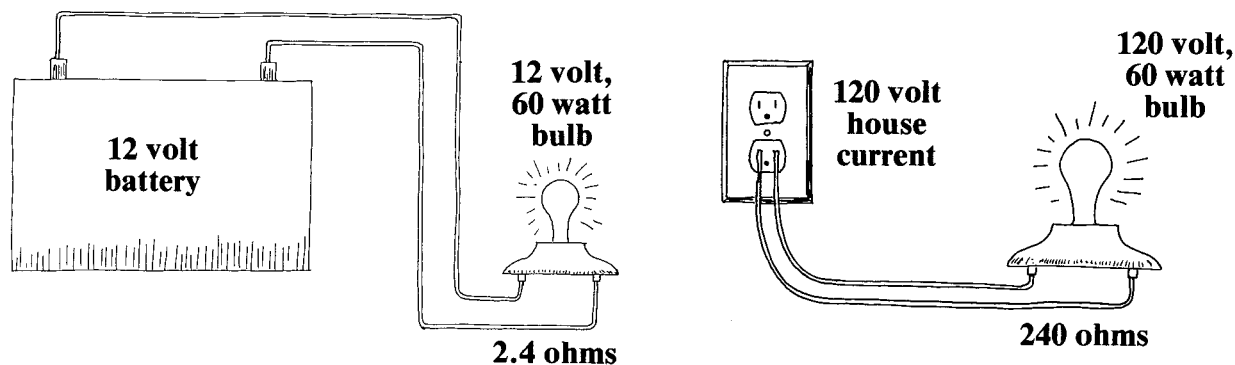

The 12 volt, 60 watt bulb that burned out in just a couple of seconds had only 2.4 ohms of resistance. We can increase the resistance inside the bulb by using smaller wire. If we hook up a 120 volt, 60 watt bulb to the 120 volt house current, the bulb puts out the same amount of light as the 12 volt, 60 watt bulb hooked up to the 12 volt battery. The 120 volt bulb has 240 ohms of resistance, so only $\frac{1}{2}$ amp of electricity can go through it. That's like using a small water pipe. The 12 volt bulb has only 2.4 ohms, so 5 amps (10 times more) of electricity can go through it. The 120 volt current lights its bulb with only $\frac{1}{2}$ amp of electricity. The 12 volt battery lights its bulb with 5 amps of electricity. In each case, the work performed by electricity is the same:

$$120 \text{ volts} \times \frac{1}{2} \text{ amp} = 60 \text{ watts}$$

$$12 \text{ volts} \times 5 \text{ amps} = 60 \text{ watts}$$

	40. The large flow of water from the high tank was resisted with a (<i>large diameter, small diameter</i>) pipe.
40. <i>small diameter</i>	41. Amperage is resisted more with wire of (<i>large diameter, small diameter</i>).
41. <i>small diameter</i>	42. The smaller the wire, the (<i>more, less</i>) the resistance.
42. <i>more</i>	43. Resistance is measured in (<i>amps, volts, ohms</i>).
43. <i>ohms</i>	44. Increasing resistance (<i>lowers, increases</i>) amperage.
44. <i>lowers</i>	45. The resistance of a light bulb is increased with a (<i>smaller, larger</i>) wire inside the bulb.
45. <i>smaller</i>	46. One 60 watt bulb is rated for 12 volts, and another for 120 volts. Which bulb has more resistance in it?
46. <i>120 v.</i>	47. A 12 volt battery has less electrical pressure, or voltage, than 120 volt house current. Therefore to light a bulb with a 12 volt battery, (<i>more, less</i>) amperage is needed than with 120 volt house current.
47. <i>more</i>	48. Low amperage and high voltage puts out as much energy as (<i>high, low</i>) amperage and (<i>high, low</i>) voltage.
48. <i>high, low</i>	49. Work performed by electricity is measured in (<i>amps, volts, ohms, watts</i>).
49. <i>watts</i>	50. volts x (<i>amps, ohms</i>) = watts
50. <i>amps</i>	51. Does voltage alone determine how much electricity is used to light a light bulb? (<i>yes, no</i>)
51. <i>no</i>	52. Does current flow, or amperage, alone determine how much electricity is used to heat an electric blanket? (<i>yes, no</i>)
52. <i>no</i>	53. Watts are used to measure electrical consumption because watts take into account both current flow and (<i>resistance, electrical pressure</i>).
53. <i>electrical pressure</i>	54. 120 volts x ½ amp is (<i>equal to, more than</i>) 12 volts x 5 amps.
54. <i>equal to</i>	55. The more the ohms, the (<i>more, less</i>) the current flow.
55. <i>less</i>	56. A thin wire has (<i>more, fewer</i>) ohms than a thick wire.
56. <i>more</i>	57. Ohms are comparable to a (<i>water dam, pipe</i>).
57. <i>water dam</i>	58. Voltage is comparable to (<i>water pressure, gallons per minute</i>).
58. <i>water pressure</i>	59. Amperage is (<i>increased, reduced</i>) with an increase in ohms.
59. <i>reduced</i>	

The complete circuit

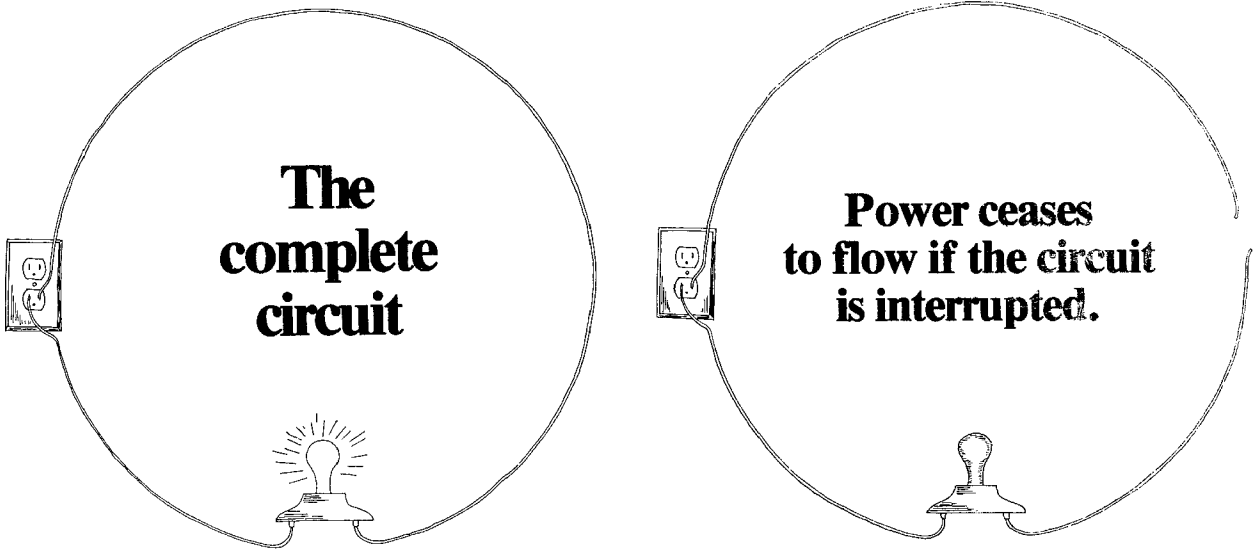

The complete circuit

Power ceases to flow if the circuit is interrupted.

When electricity flows from its source, such as 120 volt house current, to light a light bulb, it must also return to its source. Electricity must flow in an unbroken circuit. If the circuit is broken, electricity stops flowing. Every time you turn on a wall switch, you are completing the electric circuit to a light bulb. When you turn the switch off, you are interrupting the circuit.

The series circuit

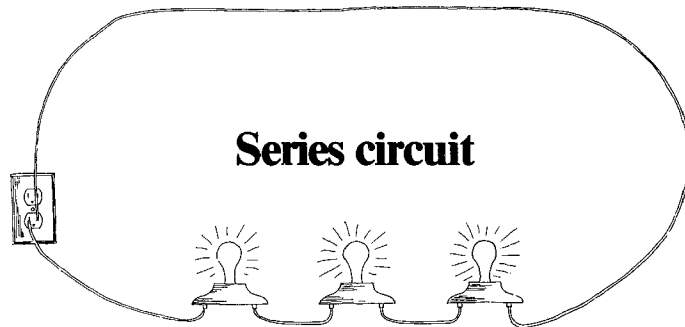

$$5 \text{ ohms} + 5 \text{ ohms} + 10 \text{ ohms} = 20 \text{ ohms}$$

There are 2 basic types of circuits: series and parallel. When several light bulbs are connected in the circuit side by side, the circuit is a series circuit. The electricity goes through the first bulb, then the second, and finally the third to travel through the circuit. Each bulb is an obstacle to the electricity. The obstacle of each bulb is measured in ohms. All the obstacles, or ohms, in a series circuit are added to make the total. Ohms are also called resistance.

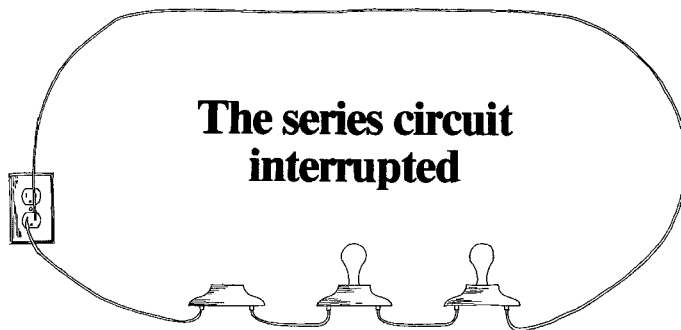

If one bulb in the series circuit is removed, the other two light bulbs will no longer work. Removing a bulb puts a gap in the circuit so that current can no longer return to its source. If a switch is added to the series circuit, the switch turns off all the light bulbs. You cannot have one bulb on and the others off. They are either all on or all off.

60. An electric circuit is interrupted when a wall switch is turned (*on, off*).

60. *off*

61. When 3 light bulbs are wired in series and 1 burns out, the other 2 (*will, will not*) glow.

61. *will not*

62. If two 5 ohm light bulbs are wired in series, their total resistance is (*5, 10, 2*) ohms.

62. *10*

The parallel circuit

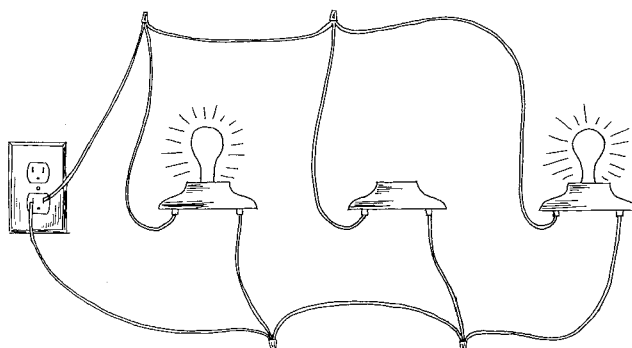
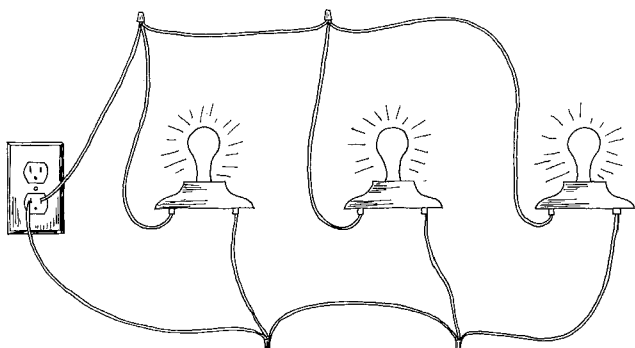

The second type of circuit is the parallel circuit. In this type, electricity flows to each light bulb without having to flow through the others. If one bulb burns out, the other bulbs continue to work.

A switch can be placed in a parallel circuit to control all the light bulbs, or each light bulb can have its own switch.

In this circuit, one switch controls all three light bulbs.

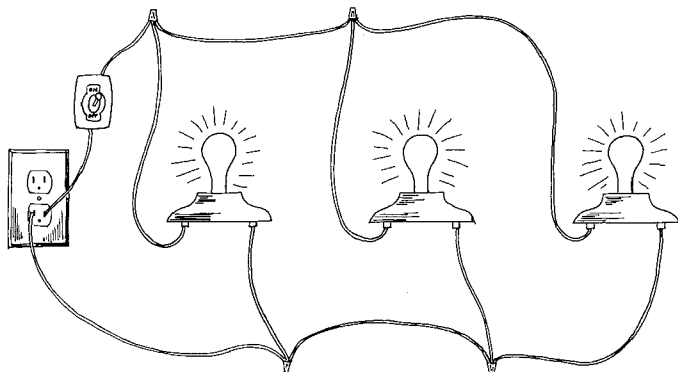

In this circuit, each light bulb is controlled by its own switch.

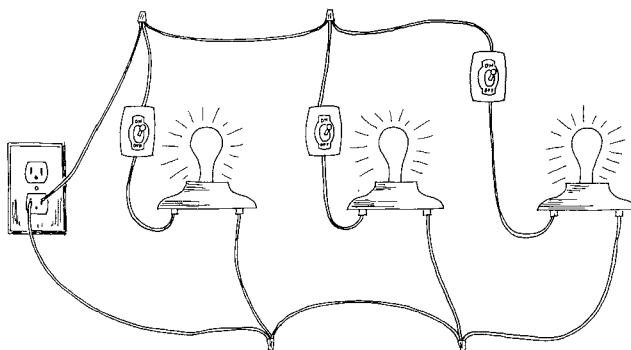

$$5 \text{ ohms} + 5 \text{ ohms} + 10 \text{ ohms} = 2 \text{ ohms}$$

Adding resistance

In a series circuit, the total resistance, or ohms, of the circuit is all the individual resistances added up. If the ohms of 3 light bulbs are 10, 5, and 5, the total ohms is 20. But in a parallel circuit, the total resistance is always *less* than the least resistance of any individual bulb. If 3 light bulbs wired in parallel have 10, 5, and 5 ohms, the total ohms of the circuit is only 2 ohms.

63. In a (*series, parallel*) circuit, a switch can be wired to control either part or all of the circuit.

63. *parallel*

64. The total resistance of a parallel circuit is (*less, more*) than individual resistances.

64. *less*

65. Raising resistance (*raises, lowers*) amperage.

65. *lowers*

66. Raising voltage pushes (*more, fewer*) electrons through a wire.

66. *more*

67. Raising voltage (*raises, lowers*) amperage.

67. *raises*

68. Amperage is comparable to (*a water pipe, gallons per minute*).

68. *gallons per minute*

69. volts x amps = (*ohms, watts*).

69. *watts*

Short circuits

When there is no resistance to the electricity in a circuit, the current flows in great quantity. This is like hooking up a big pipe to the high water tank. With nothing to hold the electricity back, the electricity flows at the maximum the voltage will permit. This can overheat and even burn wire.

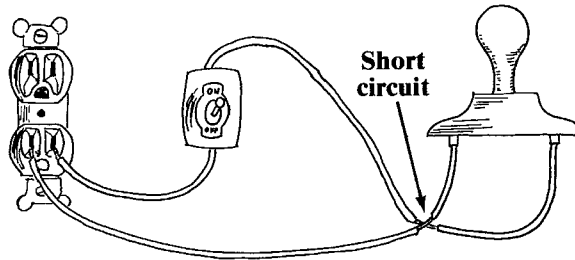

Damaged insulation on wire exposes bare wire, resulting in short circuits. In the circuit above, two bare wires have touched each other. This contact allows the electricity to complete the circuit without going through the light bulb. It bypasses the light bulb. Because the light bulb is no longer part of the circuit, the current flows with very little resistance, and it can melt the wires. But if a fuse is in the circuit, the fuse will melt before the wire can overheat.

70. Decreasing resistance (*raises, lowers*) amperage.

70. *raises*

71. Too much (*amperage, resistance*) can cause wires to melt.

71. *amperage*

72. A 120 volt light bulb has (*more, less*) resistance than a 12 volt light bulb of equal wattage.

72. *more*

73. The shorter the wire, the (*more, less*) its resistance.

73. *less*

74. A fuse blows (*before, after*) the wiring of the circuit overheats.

74. *before*

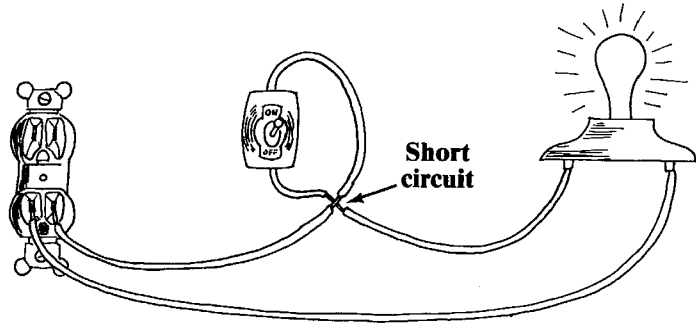

In the circuit above, bare wires have touched near the switch. Current then flows past the switch, so the switch is no longer part of the circuit. The light bulb stays on all the time whether the switch is on or not. But since the light bulb is still in the circuit, the wire does not overheat. The resistance (ohms) of the light bulb prevents too many amps from flowing through the circuit.

75. A short circuit always blows a fuse. (*true, false*)

75. *false*

76. Electrical pressure, the force that drives electrons through a wire, is measured in (*volts, amps, watts*).

76. *volts*

77. Wattage is calculated by multiplying amps times (*volts, ohms*).

77. *volts*

78. To produce 120 watts from a 12 volt battery, how many amps must flow through the circuit? _____

78. *10*

79. Adding resistance to the circuit (*increases, decreases*) amperage.

79. *decreases*

80. An amp is comparable to (*a gallon, a pound of pressure*).

80. *a gallon*

Grounding

Electricity must travel in a complete circle. In the electrical system of a building, the electricity can flow through the ground to complete the circle back to its source. This is because the source is grounded. The connection to ground is usually made by clamping the wire to a cold water pipe. You needn't know exactly how the power supply is grounded; all you need know is that electricity can travel through the ground to complete the electrical circuit back to its source.

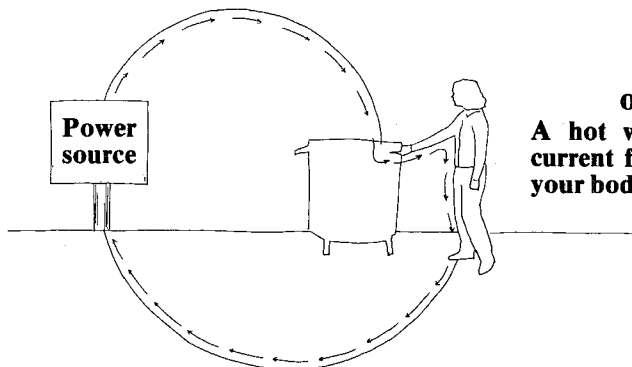

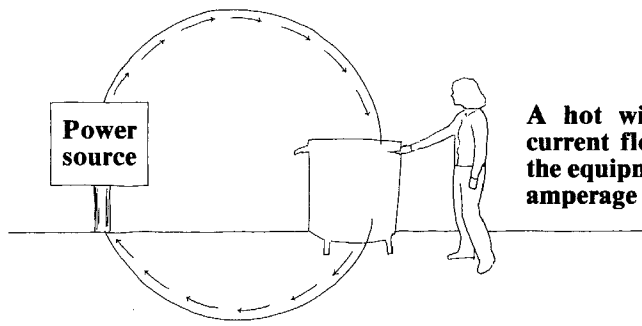

The safety of a grounded kiln:

A hot wire touches the case, and the current flows back to its source through the equipment grounding wire. This heavy amperage blows a fuse.

If a bare “hot” wire touches the case of a kiln, then touching the case is the same as touching the live wire. You’ll be touching the live wire indirectly. So if you touch the case, the case isn’t grounded, and you’re standing on a concrete floor, you could get shocked. The electricity travels through your body back to the ground to return to its source.

But if an equipment grounding wire is attached to the case, the shock hazard is greatly reduced. The electricity will go to the earth through the grounding wire instead of through you. The electricity follows the easiest path back to its source, which is the grounding wire. The equipment grounding wire is always green, or white or yellow with green stripes.

-
81. *the kiln case*
-
82. *grounding wire*
-
83. *ground*
-
84. *a cold water pipe*
-
85. *short circuit*
-
86. *too much*
-
87. *resistance*
-
88. *increases*
-
89. *watts*
-
90. *green*
-
81. The green equipment grounding wire is connected to *(the kiln’s elements, the kiln case)*.
-
82. Touching the kiln’s case is the same as touching the *(elements, grounding wire)*.
-
83. One end of the green wire is connected to the kiln case. The other end is connected to the *(power supply, ground)*.
-
84. The green equipment grounding wire is attached to the ground usually by a connection to a cold water pipe. Touching the kiln case is like touching *(the fuse, a cold water pipe)*.
-
85. The green wire gives a hot wire touching the kiln’s case a complete circuit back to the power source. If you plug in the kiln and a fuse blows immediately, there is a *(short circuit, disconnected green wire)* somewhere in the kiln.
-
86. A fuse blows when *(too much, too little)* current is flowing through a circuit.
-
87. What holds back current? *(resistance, amperage)*
-
88. Increasing voltage *(decreases, increases)* wattage.
-
89. amps x volts = *(ohms, gallons, watts)*
-
90. The equipment grounding wire is *(blue, green, red)*.
-

The 2-phase, 120/240 volt circuit

Most homes are supplied with power through 3 wires: red, black, and white. 120 volts flows through both the red and black “hot” wires. The white wire is called the line neutral and is grounded at the power source. One hot wire and the white neutral wire are used to make a 120 volt circuit. When both hot wires are used without the white neutral wire, the circuit is 240 volts.

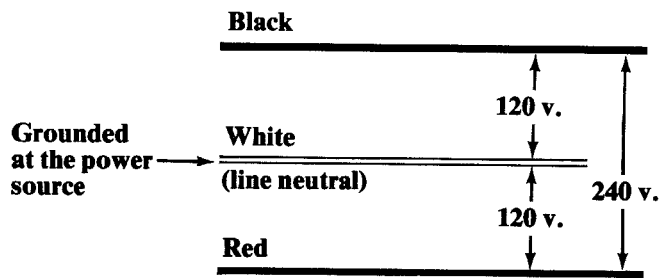

91. The line neutral wire is (*red, green, white*).
91. *white*
92. A circuit consisting of a black wire and white wire is (*120, 240*) volts.
92. *120*
93. A circuit consisting of a black wire and red wire is (*120, 240*) volts.
93. *240*
94. Touching a cold water pipe is like touching the (*red, white*) wire.
94. *white*
95. A water dam is comparable to (*volts, watts, ohms*).
95. *ohms*
96. Amps are driven through wires by (*ohms, volts*).
96. *volts*
97. Current flow is called amperage. Voltage causes the current to flow. Resistance hinders the current flow. The work performed by electricity takes into consideration both current flow and electrical pressure. Work is measured in (*ohms, watts*).
97. *watts*
98. (*Volts, Ohms*) resist the amps.
98. *Ohms*
99. Power of 120 volts and 20 amps measures (*240, 2400, 120*) watts.
99. *2400*
100. 3 light bulbs wired in series each have 10 ohms of resistance. What is the total resistance? (*10 ohms, 20 ohms, 30 ohms*).
100. *30 ohms*
101. 3 light bulbs wired in parallel each have 10 ohms of resistance. The total resistance is (*more, less*) than 10 ohms.
101. *less*
102. A grounding wire is a safety wire. It is connected to (*the switch, the kiln case*).
102. *the kiln case*
103. Current flow is measured in _____.
103. *amps*
104. Resistance is measured in _____.
104. *ohms*
105. When 2 10 ohm heating elements are wired together in a series circuit, the total resistance is _____.
105. *20 ohms*
106. When 2 10 ohm heating elements are wired in a parallel circuit, their total resistance is (*more, less*) than if they had been wired in a series circuit.
106. *less*
107. Since the 2 elements have less total resistance when wired in parallel than in series, more amps of electricity flow through the elements in a (*series, parallel*) circuit.
107. *parallel*
108. The more amps flowing through the elements, the greater the heat produced. Therefore, the elements produce more heat when wired in (*series, parallel*).
108. *parallel*
109. Electrical pressure is measured in _____.
109. *volts*

110. If 2 heating elements are wired in series and one element breaks, will the other element continue to heat? (*yes, no*)

110. *no*

111. If 2 heating elements are wired in parallel and one element breaks, will the other element continue to heat? (*yes, no*)

111. *yes*

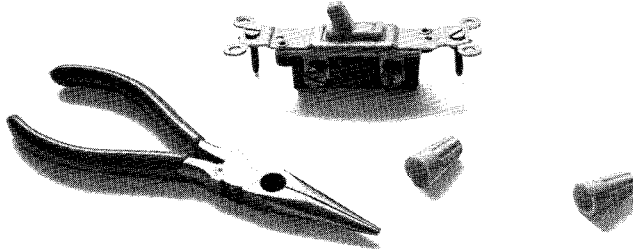

USEFUL FORMULAS

watts = amps² x ohms

watts = volts x amps

volts = amps x ohms

watts = volts² ÷ ohms

amps = volts ÷ ohms

ohms = volts ÷ amps

Resistance of a Circuit

Series Circuit: The total resistance is the sum of all individual resistances.

Parallel Circuit: The total resistance is always less than the least individual resistance.

Paragon Industries, Inc.
 2011 South Town East Blvd.
Mesquite, Texas 75149-1122
 972-288-7557
Fax: 972-222-0646



Paragon Industries, Inc.



2011 South Town East Blvd.
Mesquite, Texas 75149-1122

972-288-7557

Fax: 972-222-0646

