

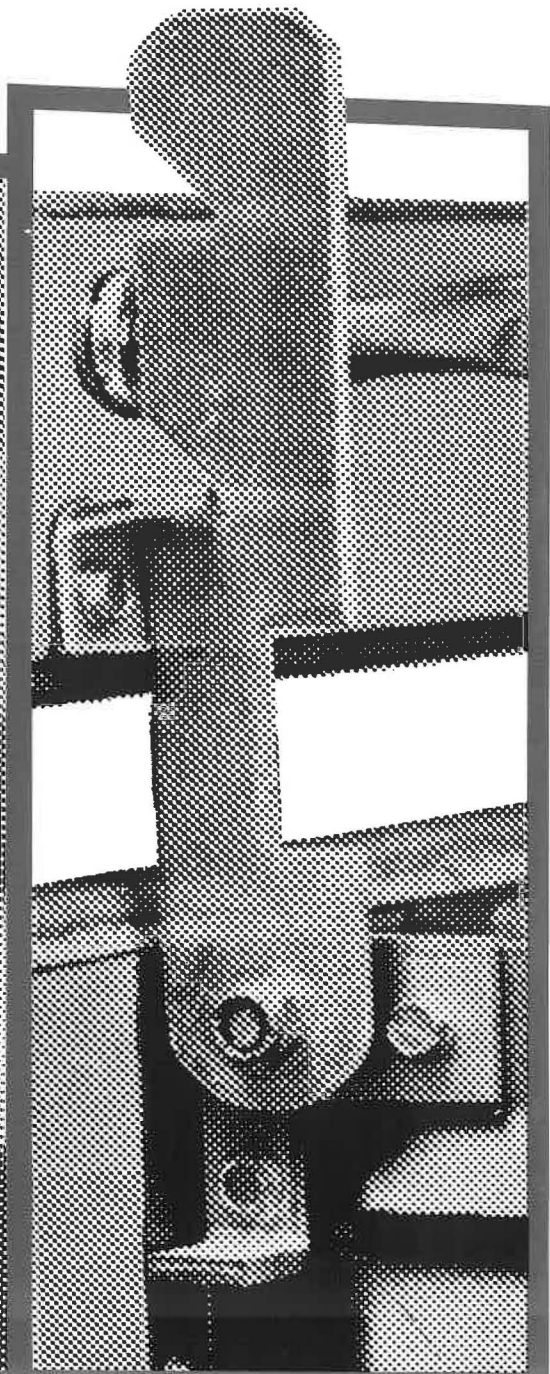

PARAGON KILNS

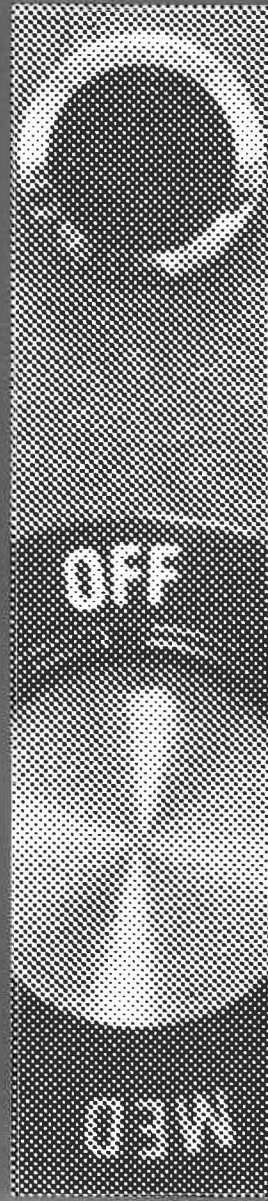

A and B series instruction and service manual

INTRODUCTION

Paragon's Instruction and Service Manual is compiled for what its title suggests. As the most authoritative source on kiln operation, this manual will tell you how to install, how to fire, and how to maintain your kiln. The time you spend in getting acquainted with your kiln and the information you will obtain from reading this manual will save you many dollars in ruined ware, as well as teach you how to get the most enjoyment out of ceramics. However, *IT IS YOUR RESPONSIBILITY TO READ IT!*

Our manual cannot possibly cover all the many phases of ceramics. That was not our purpose in preparing it. The intent is only to give you the maximum amount of information about your kiln.

Your Paragon kiln will give you years of service only if you care for it properly. It should not be considered as a household appliance which will stay looking factory new forever, but as a piece of very hard working machinery, since temperatures required for ceramics are well above the melting point of most metals, and tremendous stresses are generated within the kiln during the firing period. The insulating firebrick actually expand and contract with each firing. This is absolutely necessary for the long life of your kiln; however, hairline cracks will appear in the brick while the kiln is cold. Do not be concerned with these, as they close tightly when the heated brick expands.

There is nothing mysterious or complex about your kiln, and you have no reason to be afraid of it. No two kilns are exactly alike, even if the same brand and model. While you may have fired another kiln for years, it is still necessary that you follow each step of this manual in getting to know your new kiln. Just as every cooking stove will have different baking characteristics, every kiln will have its own personality. For this reason, the enclosed Recommended Firing Schedule Poster was not designed to be precise, as conditions affecting the kiln vary immensely. The schedules and charts of the manual are meant only as a guide to help you begin your own schedule. After you have read and studied the information herein, don't be afraid to experiment; you'll enjoy it once you start.

Your kiln dealer will be glad to help you with your problems and give you suggestions for better firing. If you should have any problems with your kiln or with its operation, see or write your dealer from whom you bought your kiln. Writing the factory first will normally only delay assistance.

CONTENTS

BEFORE YOU FIRE

Unpacking The Kiln	2
Setting Up The Stand	2
Seating The Elements	2
Cleaning The Kiln	2
Locating The Kiln	3

ELECTRICAL

Information For The Kiln Owner	4
For Your Electrician	5
Locating Electrical Trouble	7

KILN PARTS

Kiln Brick	8
Elements	8
Form-Fitted Jacket	8
Peepholes	8
Peephole Plugs	8
Operating Instructions	9
Prop-R-Vent	9
Lock-In Lid Support	9
Switches	9
Hand Lifts	9
Full-Formed Steel Base	9

KILN-SITTER

Adjustment	11
Operation	12

LIMIT TIMER

Added Steps For Limit Timer Operation	15
About Your Kiln-Sitter (With or Without Limit Timer)	15

FURNITURE

Shelves, Posts, Stilts	16
Recommended Furniture Kits	17

NECESSITIES

Pyrometric Cones	18
------------------------	----

PYROMETER

.....	20
-------	----

KEEP YOUR KILN

IN TOP CONDITION	20
------------------------	----

TEMPERING YOUR KILN

.....	21
-------	----

FIRST FIRING

.....	21
-------	----

LOAD AND FIRE

Planning The Load	22
Firing (General Instructions)	23
Switch Controls	24
Low-Fire Greenware	26
Low-Fire Glaze	27
Porcelain Greenware	28
Porcelain Glaze	29
Overglaze	30
Stoneware	31
Glass Painting	31
Glass Sagging	31

IMPERFECTION

.....	32
-------	----

USING YOUR KILN

Do's and Don'ts	34
Vocabulary	35

MAINTENANCE

Element Maintenance	36
Element Replacement	37
Lid Maintenance	39
Bottom Maintenance	39
Sidewall Maintenance	40
Switch Replacement	42

SWITCH EQUIVALENT CHARTS

.....	44
-------	----

WARRANTY

.....	Inside Back Cover
-------	-------------------



IMPORTANT

Read each page of this manual in detail before you install or operate your kiln. Warranty does not cover damage caused by failure to follow instructions.

Toxic Glazes

Some glazes may be unsafe and toxic when used for surfaces that will be in contact with food or drink. When you make food or drink containers, select a glaze that has been formulated, tested and labeled as approved for surfaces that will be in contact with food or drink. Follow the glaze manufacturer's instructions exactly, without any variations.

Important Safety Rules

An electric ceramic kiln is extremely safe to operate provided you follow these basic safety rules:

- Do not touch hot sides.
- Keep unsupervised children away.
- Place kiln on stand before connecting power.
- Do not install closer than 12" from any wall or combustible surface.
- Do not open lid until kiln has cooled and all switches are turned off.
- Fire only in well ventilated, covered and protected area.
- Dangerous voltage: Do not touch heating elements with anything.
- Disconnect kiln before servicing.

BETTER BEFORE YOU FIRE

UNPACKING THE KILN

Paragon makes every effort to insure that your kiln arrives in excellent condition. We cut no corners in our packing materials and take every possible precaution against freight damage. Acting as your agent in engaging a freight carrier, Paragon's legal responsibility ceases when the merchandise is delivered to the carrier in good condition. In shipment, however, the crate is handled by strangers who are unaware of the fragile components of a kiln and freight damage may occur.

You should thoroughly inspect your kiln as soon as it is received. If damage is discovered, you must follow the procedure below in order for the carrier to allow any claims for damage.

1. Notify your freight agent at once and request an inspection.
2. Save all of the packing materials for inspection by the freight claims adjuster.
3. Refer to your packing list for added information or contact your Paragon Kiln Dealer.

SETTING UP THE STAND

Your Paragon kiln stand has been specially designed for maximum support of your particular model. The kiln should be operated only on this stand.

1. Place the stand legs *INSIDE* the stand frame and tighten all metal screws firmly. Do not overtighten.
2. Insert the mar-proof plastic tips on the stand legs.
3. Position the stand on a concrete floor or a high temperature (protective) sheet making sure it is level. The stand *MUST* be level to alleviate stress on the kiln during firing and to prevent your glazed pieces from falling off their stilts.
4. To level, place a shim *UNDER* the appropriate leg or legs, not between kiln's bottom and stand.
5. Center the kiln's bottom on the stand providing for a minimum of 12 inches clearance between kiln and the closest wall.
6. Check to make sure the kiln sits sturdy.



SEATING THE ELEMENTS

We take every precaution to buffer our product against vibration and jarring during shipment. But a kiln is fragile and the elements inside will sometimes become dislodged. By performing our simple kitchen knife test now, you may be saving yourself time, as well as trouble later on.

KITCHEN KNIFE TEST

Press the elements into their grooves by running a blunt kitchen knife completely around each groove. Do this before the kiln is ever fired, because it may not be evident to the eye whether or not the coil is securely in its groove. If the element doesn't lie flat in the bottom of its groove, you needn't be concerned as long as the element fits all the way back into each corner and doesn't bulge outside the groove. In fact, elements will not lie flat in their grooves in the terminal bricks (right behind switch box) or the peephole bricks. It's normal.

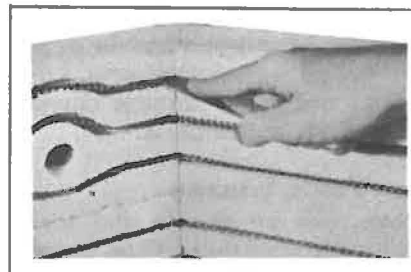

Before the kiln is fired there is no danger of breaking the elements. After firing, however, the elements must be resealed if they come out. To reseat the elements after firing the kiln, turn the switch(es) to HIGH and allow them to heat to a dull red glow. Then turn the switch(es) to OFF and *UNPLUG* the kiln. Press element coils back and down in recess with a kitchen knife while they are still warm. If allowed to cool, they become brittle and will break.

CLEANING THE KILN

Your kiln should be thoroughly cleaned before it is fired. By placing a soft, brush type nozzle attachment to a vacuum cleaner, you can remove any brick dust inside the kiln, especially in the grooves. A damp cloth or damp sponge may also be used to gently wipe dust from sidewalls and kiln's brick bottom.

LOCATING THE KILN

Convenience is the main thing to consider in locating your kiln. But equally important, is to insure the safety of the kiln's operation. The following cautions should be taken to warrant both:

- Plan your firing area near a present electrical outlet or where a new circuit can be easily and economically installed.
- Place your kiln in a well-ventilated, covered and protected area as for example, the garage, basement, utility or ceramic hobby room.
- Provide for a minimum of 12 inches clearance between kiln and the closest wall.
- Never place the kiln near curtains or other combustible materials.
- Position kiln stand on a level surface that will not be damaged by heat. A cement floor is recommended.
- Avoid placing the kiln stand on rubber tile, linoleum or any surface that might tend to mar or discolor when heated.
- Place kiln in an area where it can be easily loaded and unloaded, but out of the way when not in use.
- Keep unsupervised children away from the firing area.
- Do not allow kiln's power supply cord to come into direct contact with the side of the kiln. Your kiln jacket will become hot during firing and touching could cause damage to the cord set.
- Avoid placing kiln's power supply cord so near kiln-sitter exterior that it interferes with travel of falling weight. Cord interference with kiln-sitter weight could cause overfiring.
- There is little danger of serious burn from accidental contact if you use the same caution used with an electric iron.

INFORMATION FOR THE KILN OWNER

Your new kiln will perform properly only if plugged into an electrical outlet with enough of the proper power. Otherwise, your first firing will be disappointing or even harmful to your kiln. If you plan to use an existing circuit, it is recommended that you consult a qualified electrician. The circuit must be large enough, correctly connected, and never used for other purposes while the kiln is firing. The decision to use an existing circuit or have a new one installed should be based on the information found in the chart on page 6. Check the chart with your electrician and have him read the instructions before installing the circuit for your kiln. This will simplify his work and assure you of having the proper electrical circuit.

Your electrical installation will be as good as the electrician you use. While all electricians must be licensed, this does not insure their competence. Beware of the electrician who wants to make changes in the kiln or the recommended installation. The kiln's wiring and switches are of ample size for the current carried, and each kiln has three complete inspections plus being actually plugged into a properly wired receptacle and heated on all switch positions before it leaves the factory.

ELECTRICIANS TRAINED BEFORE 1965

With all due respect, electricians who have not studied changes established in 1965 will often make serious errors in connections of the nominal 120/240 volt wall receptacles. The wire connections on receptacles which are marked "W" from 1965 onward are the same connections that WERE marked "G" PRIOR to 1965. This connection of the line neutral wire must be properly made in the circuit that provides the electrical power. Failure to make the connection properly can greatly shorten the life expectancy of the elements and the switch(es) of your kiln. Please refer to page 5 showing NEMA Configurations and connection markings of receptacles manufactured after 1965.

GOOD CIRCUIT AFFECTS TIME REQUIRED TO FIRE

All references to time required to fire in this manual and the enclosed Recommended Firing Schedule Poster are based on an evenly loaded kiln operating in still air at exactly 230 volts for a nominal 120/240 volt kiln. These conditions usually are not found in actual practice, particularly exact voltage. A good circuit will deliver almost the same voltage at the kiln that is available at the meter, but the good circuit cannot correct low or high voltage supplied by your power company. This voltage may be 10% more or less than the usual 230 volts, which in turn will vary the time required to heat your kiln to a given pyrometric cone from as little as one-half the average time to more than twice the average time. When the voltage is below the minimum operating point, the kiln will never reach full temperature and can be corrected only by having the power company adjust the voltage.

Use the enclosed Recommended Firing Schedule Poster as a guide for your first firing, but do not assume, for example, that it will take exactly 4 hours to fire just because it says so on the schedule. These times are AVERAGE times, and you could have high voltage and fast firing. Every kiln installation will fire differently, and you must experiment with switching schedules until you know exactly how to fire your kiln. Don't be afraid to change the suggested times between changes of the switch position - there is little danger in harming your kiln or your ware if you watch your pyrometric cones and don't overfire the kiln.

If your kiln fires too fast, slow it down by leaving the switch(es) on LOW heat position longer. You can speed up firing by changing the switch(es) to a higher heat position sooner.

WARNING: The grounding (round blade) connection must be separate and apart from the line neutral connection. The proper function of the line neutral is altered if a connection is made between the line neutral and the grounding or bonding connection.

CHECK THE ELECTRICAL INSTALLATION

Whether you use an existing circuit or have a new one installed, you should make this check of the electrical installation before the electrician leaves.

1. Open the kiln lid and engage lock-in lid support.
2. Turn all switch(es) to HIGH heat position.
3. Watch the elements. They should come up to a dull red color over a period of several minutes for most models and never less than 10 to 15 seconds.
4. Turn the switch(es) to OFF position and unplug the kiln if any element or pair of elements turn bright red within 10 to 15 seconds. Have the electrician check to be sure the line neutral wire of the circuit is connected to the proper terminal at the fuse box or the circuit breaker box and neutral terminal "W" of the receptacle.

Failure to have this connection correct causes 240 volts to be applied across the individual 120 volt elements, which can cause damages to the elements or to the switch(es).

NEMA CONFIGURATIONS

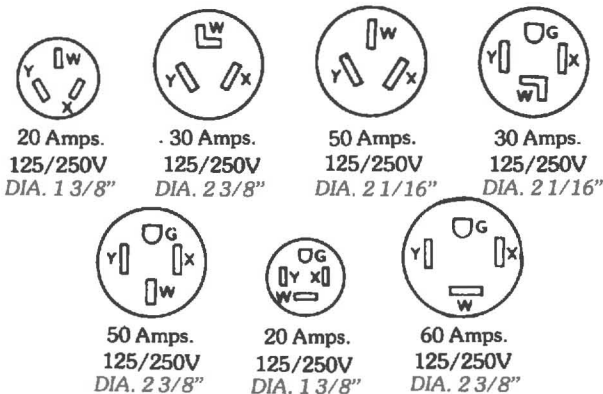

1. With probes of voltmeter in "W" and "Y", voltage should measure *NOT LESS* than 104 volts and *NOT MORE* than 130 volts.
2. With probes of voltmeter in "W" and "X", voltage should measure *NOT LESS* than 104 volts and *NOT MORE* than 130 volts.
3. With probes of voltmeter in "Y" and "X", voltage should measure between 208 and 240 volts. Very near the total voltage in steps 1 and 2.
4. Voltage from "G" and "W" should be 0 volts as proof that *NEITHER* "hot" wire is connected to "G" or "W". 0 volts is *NOT* proof that the line *NEUTRAL* wire is properly connected as it must be for correct firing and long life.

- All 120/240 volt Paragon kilns use a 3-pole, single phase grounded connection with a separate equipment bond.
- All A and B series 120/240 volt kilns use 120 volt elements.

These elements operate between the line neutral (white wire) and either side of the line. The load is balanced with the switch on HIGH heat position, but when the switch is on MEDIUM heat position the line neutral and one side of the line must carry the full current. Therefore, the line neutral wire must be of the same gauge as the hot wires. The line neutral (white wire) is a grounded conductor and not a grounding (green wire) or earthing conductor.

- The *ROUND* blade (or prong) on the plug of the kiln cord set is for equipment ground (green wire) *ONLY*.

This contact provides case (metal enclosure) grounding only. The round blade must not be confused with the line neutral (white wire) connection.

- A series kilns work equally well on circuits derived from a 208 volt, three phase service and a straight 120/240 volt, single phase circuit.

The out of phase current is carried by the line neutral wire to supply a full 120 volts to each element independently.

- Full voltage at the kiln is very important.

Low voltage causes slow firing or failure to reach full temperature in the kiln. Please refer to the following table on electrical specifications for recommended wire and fuse or circuit breaker sizes. If the circuit is more than 50 feet long, use next larger gauge wire.

- If it is necessary to change the attachment cap to fit an available receptacle, be sure to connect the line neutral (white wire) in the cord to the line neutral terminal on the new cap.

Be sure to test to see that the line neutral (white wire) is correctly connected all the way through the circuit before leaving the installation. Failure to make this connection properly could cause blown fuses, damaged switch or elements, or a dangerous electrical shock hazard. No damage caused by improper electrical installation can be covered by warranty.

- Be sure to check switch controls on page 24. Kiln must be wired properly !

ELECTRICAL SPECIFICATIONS

MODEL NO.	VOLTS	AMPS	WATTS	COPPER		RECEPTACLE OR EQUIVALENT			TYPE OF FEEDING CIRCUIT REQUIRED
				WIRE SIZE	FUSE SIZE	AH-HART	HUBBELL	RODALE	
A-23B-3	120/240	36.9	8861	8	40	5754	9450	1756	Electric Range*
A-100B	120/240	30.1	7226	6	60	9460	9460	1766	Electric Range*
AA-10B	120/240	14.1	3386	**					
Total	120/240	44.2	10612	6	60	9460	9460	1766	Electric Range*
A-99B or A-24B or A-24B-3	120/240	44.2	10612	6	60	9460	9460	1766	Electric Range*
A-88B	120/240	25.9	6226	8	40	5754	9450	1756	Electric Range*
AA-8B	120/240	8.2	1985						
Total	120/240	34.1	8211	8	40	5754	9450	1756	Electric Range*
A-82B or A-82B-3	120/240	30.0	7200	8	40	5754	9450	1756	Electric Range*
AA-8B or AA-8B-3	120/240	8.2	1985	**					
Total	120/240	38.2	9185	8	40	5754	9450	1756	Electric Range*
A-81B	120/240	30.0	7200	8	40	5754	9450	1756	Electric Range*
AA-8B	120/240	8.2	1985	**					
Total	120/240	38.2	9185	8	40	5754	9450	1756	Electric Range*
A-77B	120/240	18.4	4430	10	30	5744	9430	1736	Clothes Dryer*
A-66B or A-66B-3	120/240	15.0	3600	10	30	5744	9430	1736	Clothes Dryer*
AA-6B or AA-6B-3	120/240	6.6	1598	**					
Total	120/240	21.6	5198	10	30	5744	9430	1736	Clothes Dryer*
A-55B	120	20	2400	10	30	5716	9308		One 120 V., 30 A.
A-28B-3	120/240	46.4	11136	6	60	9460	9460	1766	Electric Range*
A-11-9B or A-11-9B-3	120	17	2040	12	20	5361	5361		One 120 V., 20 A.
A-11-6B	120	15	1800	14	15	5361	5361		One 120 V., 15 A.

* This kiln will NOT operate properly on Low, Medium and High sequence unless the grounding (round blade) is SEPARATE AND APART from the line neutral. Improper electrical installation voids all warranties, stated or implied. Therefore, check the circuit for proper wiring (see page 5) before plugging in kiln. The metal jacket grounding on dryers and stoves is often connected to the system line neutral. This connection must never be made with a Paragon kiln!

** Power for extension supplied from the kiln.

ADAPTING WYE OR DELTA THREE-PHASE POWER SUPPLY TO THE REQUIRED 120 / 240 VOLT, 3-POLE, SINGLE-PHASE GROUNDED CONNECTION WITH A SEPARATE EQUIPMENT BOND

The 120/208 volt WYE system (often called 208 volt, three-phase) has three hot poles of EQUAL voltage and a line neutral pole for a total of four poles in the system. To install the required 208 volt, single-phase, 3-pole line neutral circuit for kiln operation, the electrician would need to pull any two of the three hot poles and the one line neutral pole of the single-phase circuit with line neutral to be terminated in a standard circuit breaker box. Since all hot poles in the WYE system are equal, the electrician does not need to be concerned as to which two of the three hot poles are used, but he does need to be concerned that the line neutral pole is properly connected and that the line neutral pole is NOT confused with the third hot pole, which will not be used in the kiln circuit.

The 120/240 volt DELTA system of three-phase power requires more care on the part of the electrician. The DELTA system has three hot poles of UNEQUAL voltage and a line neutral wire for a total of four poles in the system. From the DELTA system the electrician also uses two hot poles, but he *MUST* be sure that each of the two hot poles does NOT measure more than 130 volts to ground. These two hot poles and the line neutral pole makeup the single-phase, 3-pole line neutral circuit, which will be terminated in the standard circuit breaker box. If the hot pole that measures more than 130 volts to ground is used in the kiln circuit, the kiln will have very short element life, switch problems, and other problems until the error is corrected.

LOCATING ELECTRICAL TROUBLE

If your kiln stops heating during a firing, check your fuses or circuit breakers first! In some installations, any one of four fuses can blow and prevent half of your kiln from heating. Have your electrician show you which fuses control your kiln, and how to replace them.

Wire heats when an electrical current passes through it. If the same current passes through both a small wire and a large wire, the smaller will reach a higher temperature. A fuse uses this principle to protect the wiring in a building. It has a small, short wire of low melting temperature metal connected in such a manner that all current passing through the circuit must also pass through the fuse. The fuse wire size is selected so that the maximum safe current the wiring can handle will generate enough heat to melt the wire or "blow" the fuse. A circuit breaker uses a tiny heating element to heat a thermostat which interrupts the current when the maximum safe amount is reached.

A blown fuse or tripped circuit breaker is not necessarily an indication of electrical trouble with your kiln or wiring. A short circuit or "short" causes a large amount of current to flow, generating so much heat that the fuse or breaker opens the circuit almost instantly. If your kiln should blow a fuse after firing for some time, there is little probability of a short. Replace the fuse (or reset the circuit breaker) and if it does not blow again as soon as the kiln is turned back on, there is no short in your kiln wiring.

A loose or poor connection at the fuse or breaker will generate heat. If the fuse or circuit breaker panel feel unusually warm, have your electrician check for loose connections, particularly at the center screw of the fuse socket, even in a new fuse box.

TROUBLE – SHOOTING

SLOW FIRING

Probable Cause: *Low Voltage*

Remedy: Fire kiln with all switch(es) on HIGH during entire heating cycle. If firing time remains excessive, have power company check voltage at kiln with all switch(es) on HIGH heat position. Readjust transformer if needed.

KILN DOES NOT REACH MAXIMUM TEMPERATURE

Probable Cause: *Low Voltage*

Defective Switch

Broken Element

Tripped Circuit Breaker or Blown Fuse

Remedy: Correct low voltage as above. Locate tripped circuit breaker or blown fuse by visual inspection and replace. Inspect for break. If none found, remove switch box and inspect element connections. Replace if badly oxidized. Replace switch if no other trouble is found.

HEATS IN SOME SWITCH POSITIONS...NOT IN ALL

Probable Cause: *Tripped Circuit Breaker or Blown Fuse*

Defective Element

Switch Connection

Element Connection

Remedy: Reset breaker or replace fuse. Locate defective part and replace.

FUSE BLOWS AFTER KILN HAS FIRED FOR SOME TIME

Probable Cause: *Overloaded Circuit*

Improperly Connected Line Neutral

Remedy: Remove switch box. Check to see if other appliances are being used on kiln's circuit. Check connections in wiring of building. If cap on cord set has been changed, check terminal connections.

NO HEAT IN KILN

Probable Cause: *Tripped Circuit Breaker or Blown Fuses*

Kiln Sitter Plunger Not Locked Into Position

Limit Timer Clock Not Set

Cord Not Plugged Into Outlet

Remedy: Set plunger on kiln sitter if kiln is equipped with kiln sitter. If equipped with limit timer, make sure timer clock is set before pushing in plunger. Check breaker or all fuses, including main fuses. Little probability of all elements or switch(es) failing at once.

HOT PLUG OR OUTLET

Probable Cause: *Defective Plug*

Defective Outlet

Remedy: Replace if too hot to hold. Do not fire until repaired.

KILN PARTS

KILN BRICK

Premium, hand-selected, insulating refractory brick is used for the interior of your Paragon kiln. This lightweight, porous brick is precision cut to fit tightly and store heat in the walls, bottom and lid. The form-fitted jacket snugly holds the brick in place. Kiln brick is extremely fragile and will chip easily. Keeping this in mind, you should always handle your kiln and its brick with care. Firebrick is not covered by warranty.

The temperature required for ceramics is well above the melting point of most metals, and tremendous stresses are generated during the firing period. The insulating firebrick expand and contract with each firing; a process which is absolutely necessary for the long life of your kiln. In time, hairline cracks will appear in the brick while the kiln is cold. Do not be alarmed, as the cracks close tightly during the next firing. They function as expansion joints and will not harm your kiln's operation.

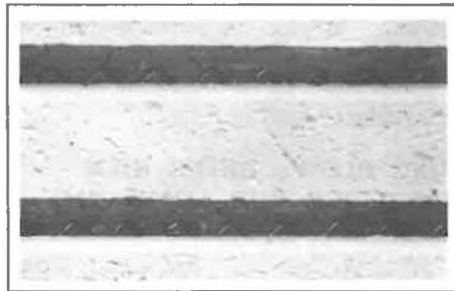

ELEMENTS

The high temperature, heavy duty alloy used in Paragon heating elements gives you at least double the life of conventional heating elements of the same size. But the life of an element is dependent upon how the kiln is used. If treated with care, an element will give efficient and economical firing to numerous loads of ware.

All high temperature, heavy duty elements must be handled carefully. They are quite brittle after being heated to a high temperature, and will break if an attempt is made to bend them while cold. By heating to a few hundred degrees (a dull red glow) and then turning the switch(es) to OFF position and unplugging the kiln, the element may be bent safely.

Never allow glaze, kiln wash or foreign materials to touch the elements, as they will destroy the element when the kiln is fired.

FORM-FITTED JACKET

The kiln jacket is specially shaped to give full support to sidewall brick and a snug fit around the firing chamber. Jacket will become hot during firing and touching could cause burns to you personally or damage to the cord set if it comes into direct contact with the jacket. Remember to provide for a minimum of 12 inches clearance between kiln and closest wall and keep combustible materials away.

Use stainless steel polish to remove smudges and stains and keep your jacket sparkling. High temperature hammertone gray paint helps protect the outer case from rust and brightens the appearance.

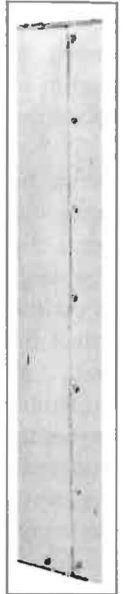

PEEPHOLES

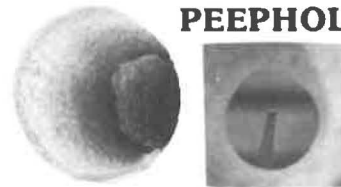

Large, see-through peepholes tapered for wide view without heat loss are used for observing the progress of your firing so you can see when the pyrometric cones bend and know when to turn the kiln off. With venting as their secondary function, peepholes allow oxygen to be drawn into the kiln's chamber and serve as an escape passage for smoke and water vapor.

When looking through the peepholes, you should always wear sun glasses. They protect your eyes from the bright light and heat of the firing chamber and make it easier to see the cones at high temperatures.

PEEPHOLE PLUGS



Peephole plugs are used to stop air from entering the kiln chamber, not to prevent heat loss. It is beneficial to have some air entering the kiln at all times so it is not necessary that the plugs fit tightly.

Never put all peephole plugs in the peepholes until the switch(es) are on HIGH heat position.

OPERATING INSTRUCTIONS

Easy to follow operating instructions are mounted on the side of most models as a ready reference in firing. The step-by-step directions and fast firing procedure make daily, routine jobs a cinch.

For superior, controlled firing of your award-winning pieces see the enclosed Recommended Firing Schedule Poster.



PROP-R-VENT

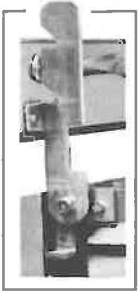

Paragon's fall away Prop-R-Vent is installed on the switch box of all A-series models to support the lid in an open position during the venting period. Adjustable in two stages, it holds the lid in its venting position (first stage) to allow gases and water vapor produced by the ware to escape. For lusters and other overglazes, the Prop-R-Vent may be engaged in its second stage for additional venting.

Prop-R-Vent and lid handle will be hot after the venting period. To protect your hands against injury, use a padded glove or thick cloth to slightly raise the lid with the handle and Prop-R-Vent will fall away to its resting position. Lower lid gently, as warranty does not cover damage to kiln or ware due to dropped lid.

Do not use Prop-R-Vent to rush the cooling process of your kiln, as this can cause damage to your ware.

Never open the lid until the kiln has cooled to room temperature.

FULL-FORMED STEEL BASE

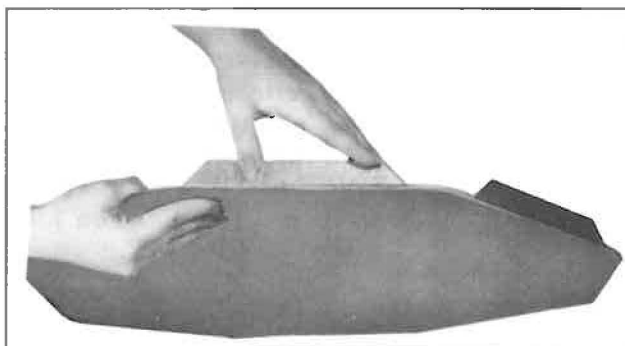

Steel base fully covers insulating brick bottom for protection and extra strength. Place ware directly on reversible brick bottom to make use of kiln's full firing capacity. 1 1/2" more firing space than competitive kilns requiring shelf and posts to be used as a false bottom.

SWITCHES

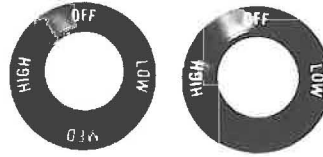

A switch is used to control the heat produced by an element or group of elements. All Paragon A and B series kilns are operated by heavy duty 4-way rotary switches, except the A-11-6B, which has a stepless control, and the rotating, extension collars, which are equipped with 3-way rotary switches.

Rotary switches allow complete firing control and flexibility to adjust the heat in the firing chamber for the best firing of each type of ware. A 4-way switch has OFF, LOW, MED, and HIGH heat positions and a 3-way switch has OFF, LOW and HIGH positions.

Stepless controls (sometimes referred to as infinite switches) use a bimetallic timer which allows the current to flow any percentage of the time from 5% to 100% of a minute. The cycling of on and off does not occur when the switch is turned to HIGH position.

The safety pilot light located above each switch glows when that section of the kiln is firing. On the collar it gives the same indication.

HAND LIFTS

Heavy duty, easily gripped hand lifts on each side of the kiln allow easy lifting and moving. Each falls back to resting position when grip is released.

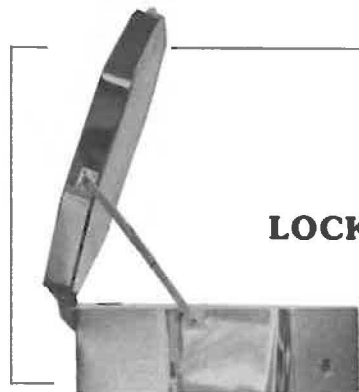
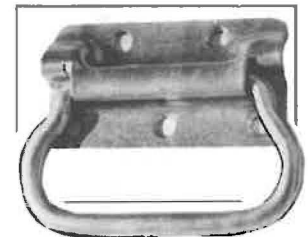

LOCK-IN LID SUPPORT

To permit easy loading and unloading, the lid support locks into place at an approximate 75° angle. Raise the lid to full extension of the lid support and gently pull the support toward you until it clicks. Release the support to close the lid by pressing the button on the inner side, and then slowly lower the lid to prevent breakage. Never open kiln lid after a firing until the kiln has cooled to room temperature.

KILN-SITTER

The kiln-sitter is a mechanical switch, that when correctly adjusted, shuts off the power to your kiln when a properly inserted, small, pyrometric cone or pyrometric bar sags under the actuating rod.

A locking slide holds the plunger in position when the plunger is pressed, causing the four contact points of the circuit breaker in the kiln-sitter to close and supply power to the kiln. When the cone or bar sags from heat, the actuating rod moves down, raising the release claw which causes the weight to fall, and the release of the locking slide and plunger. As this happens, the contact points separate and the current is interrupted or stops. If dust or foreign objects collect on the circuit breaker at the points of contact, the breaker could stick and continue to supply power to the kiln, resulting in overfire.

The primary value of the kiln-sitter is the convenience of relief from closely watching the large cones through the peepholes, and the uniform firing which can be obtained from one firing to the next. Although a properly used kiln-sitter does cut off the power to the kiln, it is a mechanical device and cannot be considered fully automatic nor relieve the user from responsibility for damage due to overfiring. It must be maintained and kept in good working order, as well as tested before *EACH* firing. Only the large cones viewed through the peepholes truly indicate the maturity of your ware and should be checked periodically, near the time the kiln-sitter is expected to shut off the power to the kiln.

Paragon supplies kiln-sitters for installation at the factory only. Even with a factory installed kiln-sitter, however, the nature of these devices prevents Paragon from extending its warranty to cover overfiring.



Your kiln-sitter was adjusted properly when shipped from the factory, but improper adjustment may result now from damage in shipping or uncrating. You must make the necessary adjustment as described on the following page before you fire. Study carefully and you will be repaid by dozens of worry-free, dependable, operating hours.

For longest life of your kiln and for safety, turn switch(es) to OFF position immediately after kiln-sitter shuts off. All kiln switches should be in OFF position before kiln-sitter plunger is pushed in. Failure to follow this step will result in extra wear on kiln-sitter contact points.

WARNING
We cannot extend our warranty to cover any damage caused by overfiring, regardless of the circumstances. You are totally responsible for the adjustment and proper operation of your kiln-sitter.
DO NOT LEAVE KILN-SITTER UNATTENDED

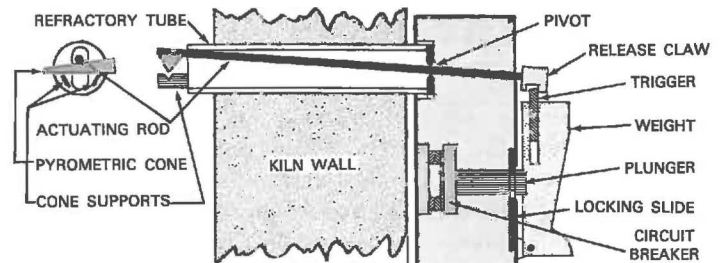

ADJUSTMENT

REFRACTORY TUBE
 FIRING GAUGE
 REMOVABLE
 CONE SUPPORTS
 ACTUATING ROD

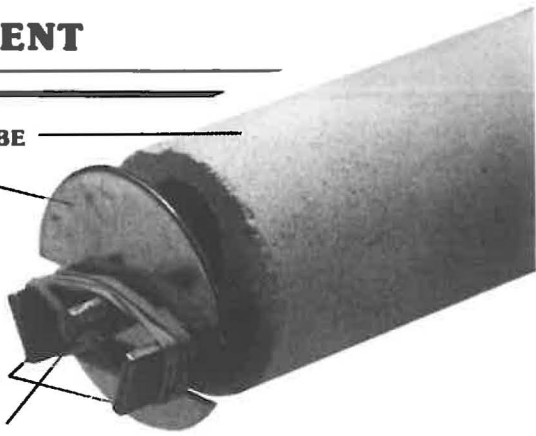

Your kiln-sitter will arrive with the firing gauge (trigger adjusting gauge) in place on the cone supports with the actuating rod inserted through the center hole. Remove the rubber band used to hold gauge in place during shipment, then remove gauge. Save the gauge for future adjustment. *Do not fire with gauge in place!*

1. Check position of actuating rod

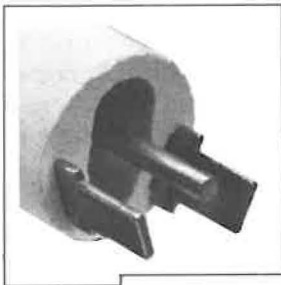

Actuating rod should be centered in oblong slot in the refractory tube. If not, loosen the two guide plate adjusting screws and move the plate to the right or left, as necessary. After rod is centered, tighten guide plate screws in place.

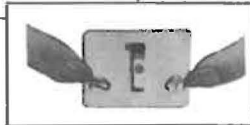
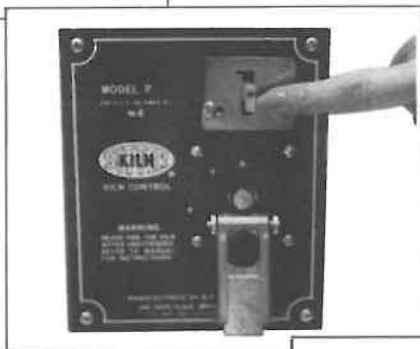

2. Test full travel of actuating rod

By holding a small mirror inside the kiln in front of the refractory tube, you can check the movement of the actuating rod. Pressing down on the release claw, rod should be free to move within the tube without touching the sides.

If rod does not fall freely to the bottom, check the guide plate to see that its slot is parallel to the direction of travel of the release claw. If not, straighten the guide plate and readjust rod centering.

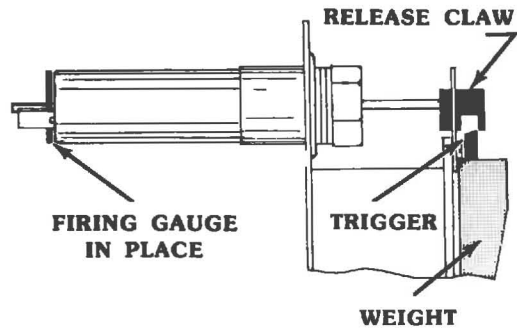

Insert end of actuating rod through hole in firing gauge (trigger adjusting gauge) on cone supports. Lift weight to the fully raised position shown. The trigger should just clear the release claw, coming as close as possible without touching. If it does not clear the release claw, loosen the set screw in center of weight, move trigger to clear and retighten set screw securely.

3. Test the mechanical operation

With all kiln switches on OFF position, raise the weight and press down the release claw over the trigger. Weight **MUST NOT** be able to stand up alone and trigger **MUST** lean against release claw.

With your other hand, hold up the end of the actuating rod inside the kiln. Remove hand from the release claw and it should hold the weight in up position while the end of the actuating rod is held up inside the kiln.

Push the plunger all the way in until it locks into position. (If limit timer is installed, time clock **MUST** be set before plunger will lock into position).

Move the actuating rod slowly downward until claw releases trigger. Weight should fall all the way to the bottom, releasing the plunger and allowing it to return to its original position. Repeat the operation at least 25 times to loosen the mechanism.

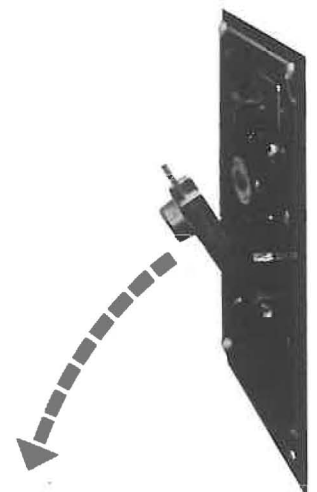
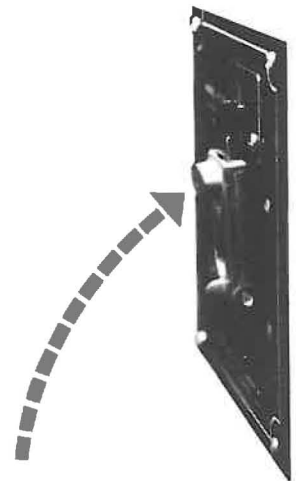

OPERATION

Regardless of your experience in firing, check the operation of any new kiln-sitter by watching large pyrometric cones placed in the kiln behind a peephole for at least 12 firings. We recommend that you use large cones for each firing; their cost is less than the smallest piece of greenware, and it is the only way to keep a check on the proper operation of your kiln-sitter or limit timer.

1. Turn kiln switch(es) to OFF position.
2. Remove metal gauge and save.

CAUTION

Do not fire with metal gauge in place! Serious damage to kiln and kiln-sitter (shut-off) will result.

3. Apply a thin coat of all-purpose, high fire, kiln wash to the upper edges of the cone supports and the lower side of the actuating rod.

WARNING

This MUST be done before each firing. Failure to do so will cause the cone to stick to the metal and prevent the kiln-sitter from shutting off the kiln. Remove old kiln wash and apply new before each firing. Do not allow kiln wash on the cone or inside the tube. Make sure the kiln wash has dried before inserting the cone.

4. Raise the weight and press the release claw down over the trigger.

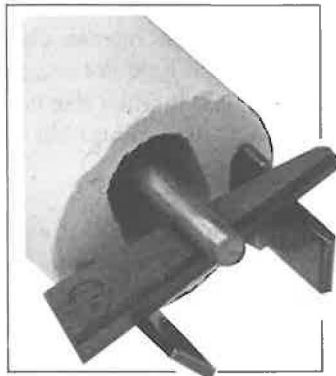

5. Place a small pyrometric cone under the actuating rod and on top of the cone supports with your other hand. You must always have at least 3/16" of the thick end of the cone extending past the cone support.

6. Load the kiln for firing, placing the correct pyrometric cones behind each peephole. (See page 22 for instructions).

Keep all ware and kiln shelves at least 1/2" away from the sides, top and bottom of the end of the cone supports and actuating rod.

CAUTION

Be sure to leave space between the cone and the end of the refractory tube. If the cone is too close to the tube, it could stick to the end of the tube and fail to shut-off the kiln.

7. Keep area around the kiln-sitter box (exterior) clear of objects which could interfere with the falling weight. The kiln-sitter weight must fall completely to the bottom of the sitter to shut off the kiln.

8. Push in the Plunger. (If limit timer is installed, timer clock **MUST** be set before plunger will lock into position).



9. Fire your ware watching the pyrometric cones through the peepholes. (See page 23 for instructions).

SELECTING THE RIGHT CONE FOR KILN-SITTER

Only small Orton pyrometric cones or the Bell bar may be used in a kiln-sitter. Either may not react to heat in exactly the same way as a pyrometric cone placed upright on the shelf. The weight of the actuating rod, the cone's horizontal position, and the way you place the cone in the kiln-sitter may cause the small cone to bend at a different temperature than an upright cone of the same cone number on the shelf.

For the first few firings, place three large pyrometric cones on a shelf a few inches from the kiln-sitter cone. One of these large cones should be the same number as the small cone or bar in the kiln-sitter, and the other two large cones should be one cone hotter and one cone cooler. For instance, if you have a small cone 05 in the kiln-sitter, the large cones on the shelf should be 04, 05, and 06.

When the kiln-sitter shuts off and the kiln cools completely, inspect the cones. If the large cone 05 on the shelf bent to six o'clock, the small kiln-sitter cone and large shelf cone should be of the same cone number during future firings. If the large cone 04 bent to six o'clock, you should use one cone cooler in the kiln-sitter than on the shelf. If large cone 06 bent to six o'clock, you should use one cone hotter in the kiln-sitter than on the shelf.

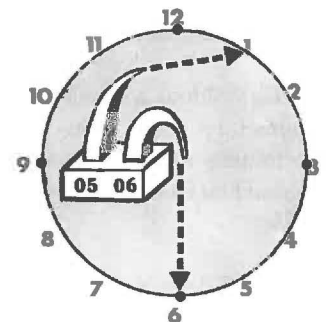
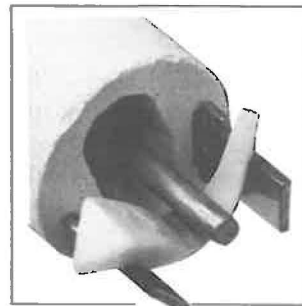

A shelf cone bends to six o'clock when it reaches maturity.

Since the ware is on the shelf where the large cones are placed, the maturity of the ware is more accurately measured by the cones on the shelf, rather than the small cone of the same number in the kiln-sitter.

To get like firings you must place the cone in the kiln-sitter in exactly the same way each time you fire your kiln. Placing the small cone as already shown will make duplicate firings easy to obtain. You *MUST* always have at least 3/16" of the thick end of the cone extending past the cone support to enable the kiln-sitter to shut-off before the cone melts and overfiring results. *Do not try to get a hotter firing except by the use of a hotter cone. Use a cooler cone for a cooler fire.* (See table on page 18).

If your kiln-sitter has been properly adjusted with the small cone correctly inserted, the cone in the kiln-sitter will be bent into a "U" shape at the end of your firing period.

SUMMARY OF KILN-SITTER OPERATION

1. Always use large cones on the kiln shelf. Make sure you can see them through the peephole.
2. Select proper small cone for the kiln-sitter.
3. Make the mechanical test shown on page 11.
4. Clean off old kiln wash from cone supports and rod and apply new before each firing.
5. If at any time the rod does not move freely, remove and clean the back of the guide plate and inside of the tube, then readjust.

WHEN KILN-SITTER SHUTS OFF BEFORE PEEPHOLE CONES BEND

1. Raise the weight.
2. Press in the plunger.
3. Very gently lower the weight until it stops.

WARNING

This puts the kiln on MANUAL CONTROL and prevents the kiln-sitter from cutting off automatically. When large peephole cones bend, turn the kiln switch(es) to OFF position.

4. Before the next firing, check the adjustment of the kiln-sitter trigger (see page 11).

WHEN PEEPHOLE CONES BEND BEFORE KILN-SITTER SHUTS OFF

1. Turn the kiln switch(es) to OFF position.
2. After the kiln has cooled, compare the small cone in the kiln-sitter with the large cones at the peepholes. If the small cone in the kiln-sitter bent normally, you may be firing the kiln unevenly.

3. Look at the cone in the kiln-sitter to determine if it has bent almost to the cut off point. In most cases, firing a few minutes longer with the kiln-sitter cutting itself off would have no adverse effect on the ware. However, you should avoid overfiring glass, reds and porcelain.

LOADING AROUND REFRACTORY TUBE

Even though your kiln-sitter has been properly adjusted and the small cone correctly inserted beneath the actuating rod, loading around the refractory tube could cause a malfunction that would result in overfiring. These points on loading your kiln should be remembered.

1. Do not place shelf too close to refractory tube. Should be at least one inch above or below the tube should the shelf expand or tilt in tubes direction.

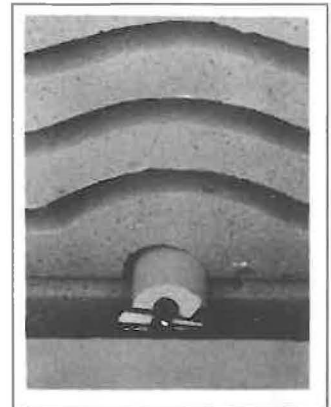

2. Do not position poorly stilted ware near end of refractory tube as it could fall against the actuating rod.



3. Never load moist greenware in your kiln. It could possibly explode and damage your kiln brick or a piece could lodge beneath the actuating rod.



LIMIT TIMER

The limit timer is a kiln-sitter plus a clock motor which functions to override the actual firing time by a few minutes and act as a back up electrical power cut off device for the kiln-sitter. It is not a substitute for pyrometric cones, but rather an added convenience.

It may be used as a timing device to help you learn to estimate firing time. For example: if the timer knob is set at 10 before firing and the white dot indicator is on 6 when firing is completed, you will know 4 hours were required to fire that amount of ware to the bending of the cone in the kiln-sitter. After you become familiar with the firing times for the different types of ware, you will be able to estimate the limit timer settings for within 15 to 30 minutes of completed firing times. This variation would prevent severe damage to the kiln with most types of loads being fired.

The limit timer may be set for any period up to twenty hours, and may be adjusted at any time during firing.

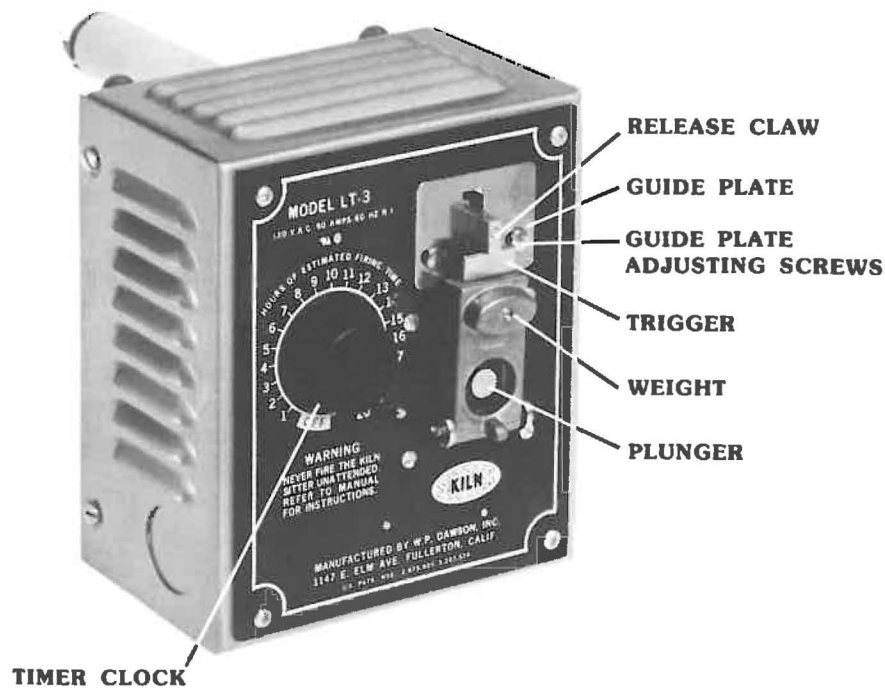

PARTS IDENTIFICATION

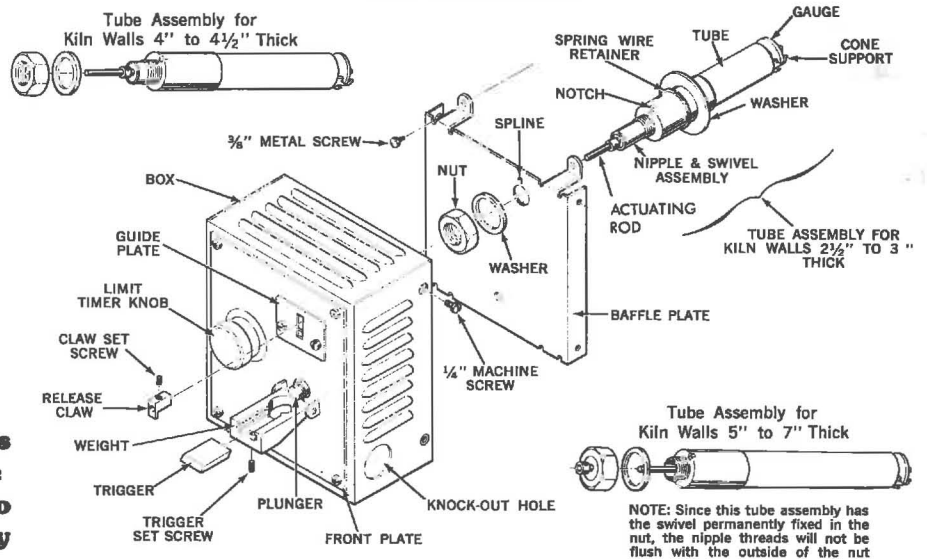

WARNING

Since proper operation and control of the limit timer rests wholly with the operator, we cannot extend our warranty to cover any damages caused by overfiring, regardless of the circumstances.

ADDED STEPS FOR LIMIT TIMER OPERATION

The difference in the operation of the kiln-sitter with limit timer as opposed to the kiln-sitter without limit timer (Model P-10) is that the timer clock **MUST** be set (for the estimated firing time plus 15 to 20 minutes) **BEFORE** the plunger of the kiln-sitter can be pushed in and the firing started. Follow all instructions for Operation of the kiln-sitter as given in preceding sections, but keep these added steps in mind.

We recommend checking the operation of the kiln-sitter with limit timer by watching large pyrometric cones placed in the kiln behind the peepholes for at least 12 firings.



1. The timer clock **MUST** be set **BEFORE** the plunger will stay locked into firing position.
2. The timer clock **STARTS** running **IMMEDIATELY** when the plunger is pushed in.
3. You must begin your firing schedule immediately after the plunger is pushed in.
4. The timer clock must be set for a longer period of time than the actual firing time. The pyrometric cone in the kiln-sitter will bend and cause the weight to drop under normal operation. If the kiln has been shut off by the limit timer without cones at the peepholes and cone in kiln-sitter bending properly, refire ware with new cones and make certain timer clock is set for 15 to 20 minutes more than the required firing time.

WARNING: DO NOT LEAVE KILN-SITTER WITH LIMIT TIMER UNATTENDED. For longest life of your kiln and for safety, turn switch(es) to OFF position immediately after kiln-sitter shuts off. All kiln switches should be in OFF position before kiln-sitter plunger is pushed in. Failure to follow this step will result in extra wear on kiln-sitter contact points.

ABOUT YOUR KILN-SITTER (With or Without Limit Timer)

- DO** check your kiln-sitter for shipping damage before firing your kiln.
- DO** learn to adjust and operate your kiln-sitter before firing.
- DO** straighten guide plate if rod does not fall freely to bottom of the oblong slot.
- DO** leave space inside kiln for rod to operate.
- DO** check kiln-sitter with pyrometric cones at the peepholes and in the kiln-sitter.
- DO** place cone in same position in kiln-sitter each time for the same firing results.
- DO** use a hotter cone for a hotter firing.
- DO** clean off old kiln wash and apply new before each firing.
- DO** check adjustments on kiln-sitter often.

- DO NOT** use your kiln before you read and understand kiln-sitter adjustment and operation.
- DO NOT** fire with the trigger adjusting gauge in place.
- DO NOT** throw trigger adjusting gauge away. You need it !
- DO NOT** load shelves and ware so close to refractory tube that either would interfere with drop of actuating rod.
- DO NOT** put anything near your kiln-sitter box (*exterior*) that will keep weight from dropping completely to bottom.
- DO NOT** let kiln wash get in the refractory tube or on pyrometric cone.
- DO NOT** adjust trigger to control shut off point.

FURNITURE

SHELVES

Shelves are flat slabs of fireclay which have been fired to a higher temperature than will be encountered in your kiln. By using shelves you can stack more ware in your kiln than you could ever place on the bottom of the kiln alone.

Shelves are made especially for the kiln in which they will be used and come in a variety of shapes. Half shelves increase kiln space by making it possible to fire tall pieces on one side of the kiln and one or more layers of small items on the opposite side.

Shelves are strong and will not sag if properly supported. But like any other pottery they will break if dropped and should be handled carefully.

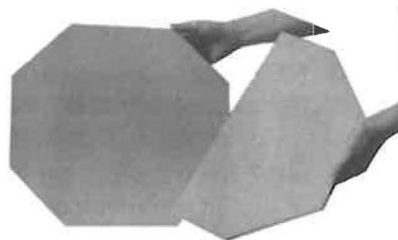

POSTS

Posts are made from the same material as shelves and will withstand the same amount of heat. They are used to support and separate the layers of shelves that are placed in your kiln.

The shorter the post, the greater the stability. Posts can be stacked upon one another to achieve a certain height, but naturally would not be as stable as a single post of equivalent size.

Posts vary in size from 1/2 inch up and are sold in lengths of even inches. The 1/2 inch and 1 inch posts are used to obtain heights not in your post assortment. Avoid the use of posts that are taller than 10 inches by placing the tall ware on the top shelf of your kiln.



STILTS

Stilts are small clay supports with points that cradle copper enameling ware and ceramic pieces for temperatures up to 2000°F. Mainly used to support glazed pieces, stilts prevent ware from sticking to the shelves during firing.

The points are made out of heat resistant metal or, frequently, from the clay itself. You can straighten the metal points as needed by applying gentle pressure with a pair of pliers. Glaze buildup on the points may be removed with an emery board or fingernail file.

Stilts are available in a wide variety of shapes and sizes for firing different objects. Be sure the stilt you select will adequately support your ware to prevent the piece from toppling over during firing.

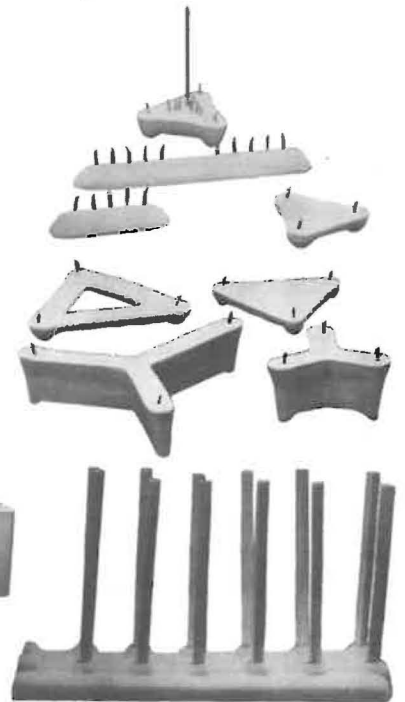

RECOMMENDED FURNITURE KITS

Carefully selected shelves and posts allow you to make the most of your kiln's firing capacity and accommodate the widest variety of ceramic work. *NOTE:* Shelves

should be 1 to 2 inches smaller than the firing chamber of the kiln in which they are to be used. If shelves are the same size or larger than the chamber, breakage will occur.

A-11-6B, A-11-9B & A-11-9B-3

1 C-10 Shelf 1 C-10H ½ Shelf
3 each - 1", 2", 3" Tri-Posts
1 lb. Bag Kiln Wash
Shpg. Wt.: 14 lbs.

A-28B-3

8 C-24H ½ Shelves
8 each - 1", 2", 3", 4", 5", 6" Square Posts
1 lb. Bag Kiln Wash
Shpg. Wt.: 164 lbs.

A-55B

1 C-10 Shelf 1 C-10H ½ Shelf
3 each - ½", 1", 2", 3", 4", 6" Tri-Posts
1 lb. Bag Kiln Wash
Shpg. Wt.: 16 lbs.

A-66B

2 C-13 Shelves 1 C-13H ½ Shelf
3 each - ½", 1", 2", 3", 4", 6" Tri-Posts
1 lb. Bag Kiln Wash
Shpg. Wt.: 21 lbs.

A-66B with Extension Collar

A-77B

3 C-13 Shelves 1 C-13H ½ Shelf
3 each - ½", 1", 2", 3", 4", 6" Tri-Posts
1 lb. Bag Kiln Wash
Shpg. Wt.: 26 lbs.

A-66B-3

2 C-14 Shelves 1 C-14H ½ Shelf
3 each - ½", 1", 2", 3", 4", 6" Tri-posts
1 lb. Bag Kiln Wash
Shpg. Wt.: 21 lbs.

A-88B & A-81B

2 C-16 Shelves 1 C-16H ½ Shelf
4 each - ½", 1", 2", 3", 4", 5", 6" Tri-Posts
1 lb. Bag Kiln Wash
Shpg. Wt.: 40 lbs.

A-82B

(Also, A-88B & A-81B with Extension Collar)

3 C-16 Shelves 1 C-16H ½ Shelf
4 each - ½", 1", 2", 3", 4", 5", 6" Tri-Posts
1 lb. Bag Kiln Wash
Shpg. Wt.: 50 lbs.

A-82B-3

3 C-18 Shelves 1 C-18H ½ Shelf
4 each - ½", 1", 2", 3", 4", 5", 6" Tri-Posts
1 lb. Bag Kiln Wash
Shpg. Wt.: 37 lb.

A-99B & A-24B

8 C-22H ½ Shelves
8 each - 1", 2", 3", 4", 5", 6" Square Posts
1 lb. Bag Kiln Wash
Shpg. Wt.: 133 lbs.

A-24B-3

8 C-23H ½ Shelves
8 each - 1", 2", 3", 4", 5", 6" Square Posts
1 lb. Bag Kiln Wash
Shpg. Wt.: 133 lbs.

A-100B

6 C-22H ½ Shelves
8 each - 1", 2", 3", 4", 5", 6" Square Posts
1 lb. Bag Kiln Wash
Shpg. Wt.: 114 lbs.

A-23B-3

6 C-23H ½ Shelves
8 each - 1", 2", 3", 4", 5", 6" Square Posts
1 lb. Bag Kiln Wash
Shpg. Wt.: 110 lbs.

NECESSITIES

PYROMETRIC CONES

Pyrometric cones are small pyramids of clay and mineral oxide that determine how long your ware should be fired. They soften and bend when exposed to heat for a period of time, and are by far the most important things you will place inside your kiln.

The maturity obtained in any firing is in direct relation to the "heat-work" produced by the kiln on the ware being fired. Time, temperature and the atmospheric condition inside the kiln control the maturity of your ceramic bodies, as well as the bending of your pyrometric cones. If the pyrometric cones are used as instructed, they will precisely measure the amount of "heat-work" done by the kiln in a single firing.

Different materials will require different firing conditions. Large and small pyrometric cones are stocked in all numbers from 022 to 10, respectively indicating the coldest to the hottest cone. The number can be found on the side or base of the cone, and the exact cone to use with each material is usually stated on the label by the clay or glaze manufacturer or your supplier can provide this information.

Selecting the correct pyrometric cones may also be influenced by the thickness of the kiln's wall. A kiln with walls less than 3 inches thick may require one cone hotter than a kiln with 3 inch or thicker sidewalls for the ware to have the same degree of maturity. The effect of the additional heat stored in the thicker wall kilns will cause the ware to mature and additional bending of the pyrometric cone after the power is turned off.

Cones should be handled with care. If dropped, abused or exposed to moisture, they may develop cracks which could effect the performance of the cones.

**Never fire by time alone . . .
always use a pyrometric cone !**

TEMPERATURE EQUIVALENTS ORTON PYROMETRIC CONES

Cone Number	Large Cones		Small Cones
	Heated at: 108° F. per hour*	270° F. per hour*	
022	1069	1086	1165
021	1116	1137	1189
020	1157	1175	1231
019	1234	1261	1333
018	1285	1323	1386
017	1341	1377	1443
016	1407	1458	1517
015	1454	1479	1549
014	1533	1540	1596
013	1596	1566	1615
012	1591	1623	1650
011	1627	1641	1680
010	1629	1641	1686
09	1679	1693	1751
08	1733	1751	1801
07	1783	1803	1846
06	1816	1830	1873
05	1888	1915	1944
04	1922	1940	2008
03	1987	2014	2068
02	2014	2048	2098
01	2043	2079	2152
1	2077	2109	2154
2	2088	2124	2154
3	2106	2134	2185
4	2134	2167	2208
5	2151	2185	2230
6	2194	2232	2291
7	2219	2264	2307
8	2257	2305	2372
9	2300	2336	2403
10	2345	2381	2426

* Rate of temperature increase during last several hundred degrees of firing.
Tables by courtesy of The Edward Orton, Jr. Ceramic Foundation

In most cases, ceramists are concerned with a firing range of 1112° F. through 2305° F. for a piece of ware to achieve its proper maturity. The pyrometric cone numbers which encompass this range are 022 through 8.

Pyrometric cones come in two sizes. Small cones (1 1/8" high) which are required in kiln-sitters and large cones (2 5/8" high). It is merely a matter of personal preference which size you use behind the peepholes. Normally, the large size is placed on the shelves of the kiln's interior, because they are more easily viewed.

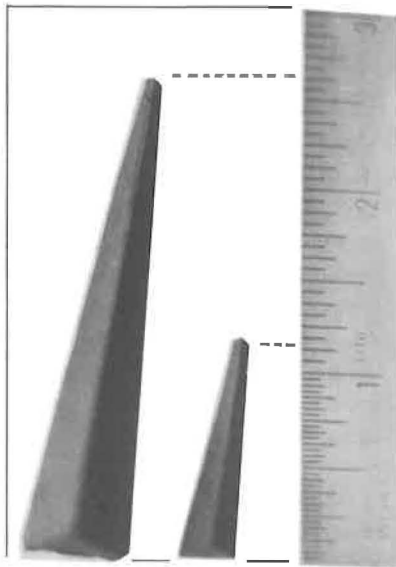

Even though they are made of the same material, the size and weight of the cone affects the bending. A larger, heavier cone will bend earlier or at a lower temperature than a small cone. The bending differential of the two sizes is insignificant with materials of reasonable firing ranges. However, you should be consistent in using either the small or large cone behind the peephole if you expect consistent results. The small cone is always required in the kiln-sitter.

The visual cones used inside the kiln must be properly mounted in order to receive consistent results. They must have their natural 8° slant from vertical position (the incline a cone has when stood on its base). If a cone is mounted at an angle greater than 8° it will bend more or at much too low a temperature, just as a cone mounted at an angle less than 8° will bend less or at too high a temperature.



Pyrometric cones may be inserted in cone holders (clay plaques or wire holders) or you can mount your cones in a pat of clay. If a pat of clay is used, it should be completely dry before firing to prevent its possibility of exploding and ruining a full load of ware. To speed drying, make indentions in the pat of clay with the end of a small brush handle after the cone is inserted.

COLOR SCALE FOR TEMPERATURES

Color	Appx. Cone	Degrees F.
Lowest visible red to dark red	022 to 019	885 to 1200
Dark red to cherry red	018 to 016	1200 to 1380
Cherry red to bright cherry red	015 to 014	1380 to 1500
Bright cherry red to orange	013 to 010	1500 to 1650
Orange to yellow	09 to 03	1650 to 2000
Yellow to light yellow	02 to 10	2000 to 2400

Mount behind each peephole a large cone of the same number as the small cone used in the kiln-sitter. Place a large cone of lower temperature beside it. For example: small cone 05 in kiln-sitter, large cones 05 and 06 behind peepholes. When the kiln has cooled and can be unloaded, examine the position of the cones in the cone plaques as they are removed. On each plaque note its location in the kiln and the load of ware on the shelf. After a period of time you can compare the results and adjust the firing schedule for your particular kiln.

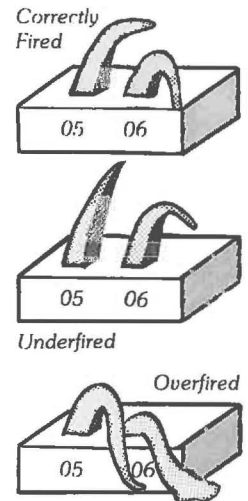

Place your large cones at least 3 inches behind the peepholes to protect them from exposure to cool air drafts and in such a position that you have a clear path of vision to the element on the opposite side. At higher temperatures a cone is difficult to see if a piece of ware is behind it. Always use dark glasses when checking the bend of your cones during firing.

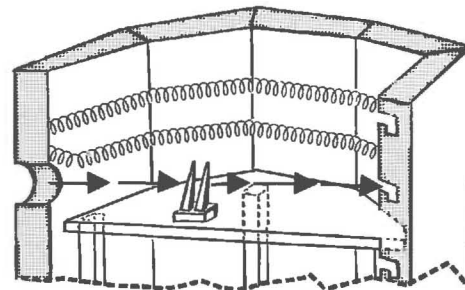

Ideally, you will be able to place your mounted cones on a shelf behind the peepholes. It may be necessary, however, to use a post to position your cones due to the size of your ware preventing a shelf behind each peephole.

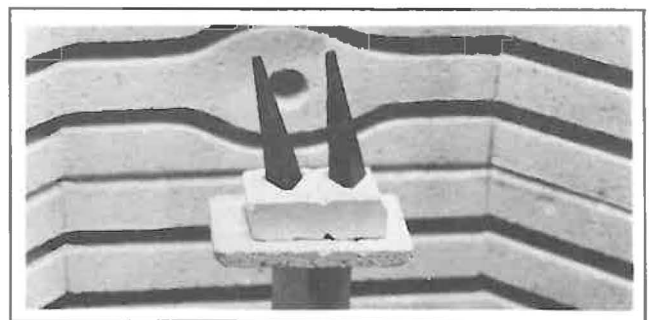

PYROMETER

A pyrometer is a portable instrument for measuring the temperature inside the kiln from approximately 100° F. to 2400° F. It consists of a thermocouple, lead wires and a temperature indicating meter mounted in a metal case. It is used to measure the progress of firing or cooling and as a guide for advancing switch positions.

A pyrometer indicates when it is time to start watching the pyrometric cone(s) closely and is an excellent way to fire quality ware consistently. It is not a substitute for a cone because a pyrometer measures temperature only, while a cone shows the amount of heat treatment which is applied to the ceramic body as it is being fired. Since a pyrometric cone is made from similar material and is subjected to the same heat treatment as the ware being fired, the pyrometric cone is the most accurate indicator of proper firing time.

The thermocouple is the measuring unit of a pyrometer which is inserted into the firing chamber of the kiln through a hole, 1/2 inch in diameter, which is drilled in one of the peephole plugs. The life of a thermocouple is in direct relation to the hours of heat applied to the thermocouple. Therefore, when firing the hi-fire materials, you will get far greater service by using the thermocouple inserted in the drilled peephole plug for taking readings during the firing process.

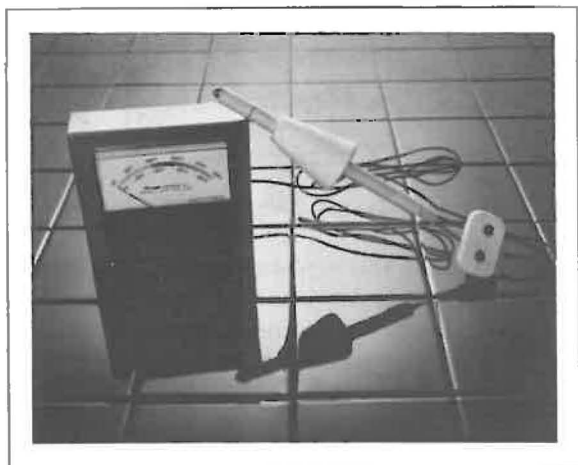

REPLACEMENT PARTS

Thermocouple for T-2 pyrometer, 8" long, 8 gauge - All kilns.
Chromel-Alumel pyrometer lead wire, 5' long.

STAINLESS STEEL POLISH

Preserves the beauty of your stainless steel kiln. Removes finger marks and firing stains instantly and safely. Handles other household chores and polishing jobs too. Removes rust and corrosion from anything. Available in 4 oz. plastic bottles.

ALL-PURPOSE, HIGH FIRE, KILN WASH

Before glazed ware, porcelain or stoneware is fired, you should protect the bottom of the kiln and the tops of shelves with all-purpose, high fire, kiln wash. A must for porcelain or stoneware firing, kiln wash is a mixture of finely ground minerals which will not melt and fuse together at temperature encountered in ordinary firing. By mixing a small portion of the powder with water to the consistency of thick cream and brushing on a thin, even coat, you will prevent glaze drips from sticking permanently to these surfaces. As a powder, it has unlimited shelf life.

All-purpose, high fire, kiln wash *MUST* be used in all kilns rated to 2300° F., even though the kiln is usually fired at lower temperatures. If a regular (ceramic) type kiln wash is fired above cone 04, it will harden and be difficult, if not impossible, to remove when hotter firings are desired at a later date.

While recoating with kiln wash is not necessary after each firing, glaze drops should be scraped off the shelves or dug out of the bottom if they appear, and a new coat applied to the bare area.

Cardboard or newspaper should be used during application to bottom of kiln to prevent kiln wash drops from touching the elements, causing them to burn out.

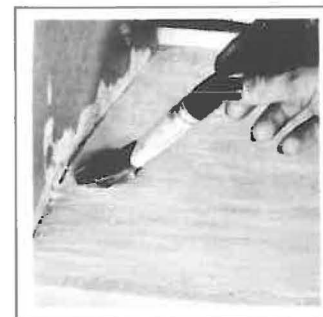

Kiln wash should NEVER be applied to kiln walls or the undersides of shelves. Available in 1 lb. and 5 lb. bags.

KILN COATING AND REPAIR CEMENT

A permanent, high-temperature, refractory cement for all types of kilns. Thin the cement with water to coffee cream consistency and replace broken brick section, repair holes and cracks or apply as dust-free coating on inner lid. (See page 36 for instructions). Available in 1 lb. bags.

HIGH TEMPERATURE GRAY HAMMERTONE PAINT

Original finish type air drying enamel to keep your kiln shining new and protect it from rust. Spray for uniform finish and best results, but may be brushed on. Specify color.

Available in 1/2 pint and 1 pint cans.



TEMPERING YOUR KILN

Your kiln will give longer and better service if broken in carefully. Moisture is present in the kiln from water used in manufacturing, and the brickwork must be dried by pre-heating. You can temper the brick and increase the life of your kiln by following this pre-heating sequence:

1. Empty and clean the kiln. (See page 2 for instructions.)
2. Make certain the elements have been seated (see page 2).
3. Close kiln lid, leaving the peephole plugs out of the peepholes.
4. Turn all switch(es) on LOW position.

While a cone is not required during pre-heating, the kiln should be checked every hour to be sure there is no electrical problem that would cause overheating. (See electrical information on page 4.)

5. Leave the kiln switch(es) on LOW for 4 hours, then turn to OFF position.
6. Keep kiln lid closed for 24 hours.

If your kiln is located in a garage or other unheated area subject to humid air and not used for several months, this tempering process should be repeated before firing your ware.

FIRST FIRINGS

After pre-heating, fire your kiln to cone 018 (or one of the other overglaze cone numbers shown on the chart on page 30). After the kiln cools, fire to cone 05. During both firings, only the kiln furniture and pyrometric cones should be in the kiln. The cone 05 firing will soften the elements to seat them properly in their recessed grooves and form a good oxide coating on the elements. This will increase your elements' life expectancy.

Foreign materials interfere with the formation of this oxide layer, so you should position only your kiln-washed shelves in your kiln with pyrometric cones placed on each. Air must circulate around the empty shelves, so use posts to separate them. The shelves may crack if you stack them in your kiln without separating them. (See next page for instructions on positioning kiln furniture.) Make sure you can see the cones through the peepholes, since the cones will indicate when your kiln has reached cone 018 and cone 05 firing maturity.

Follow each step of the Fast Firing Procedure shown on Paragon's Operating Instructions mounted on the side of your kiln for these firings, and refer to it as needed to make routine jobs easy. For superior, controlled firing, refer to the enclosed Recommended Firing Schedule Poster.

Allow the kiln to cool to room temperature before opening the lid. Cooling time is usually twice the firing time.

Make a record of how long it took your kiln to fire to cone 018 and cone 05. This information will assist you in predicting future firing times, but remember that it takes longer to fire a load of ware than a kiln loaded with just furniture and cones.

Your kiln is generating temperatures that would melt most metals! As your kiln ages, tiny hairline cracks will sometimes appear in the firebrick. This is completely normal. The hairline cracks in the firebrick close tightly when the heated brick expands.

PLANNING THE LOAD

Since all heat rises, the bottom of a kiln is the most difficult part to heat. Thus, as much of the bottom should be exposed to radiation from the sidewalls as possible.

To make maximum use of your kiln's firing capacity, group similar sizes of ware as it is prepared. Directly on the floor of the kiln, place small, light pieces with ample room for air circulation around their bases. Low pieces require less heat and will allow you to use your kiln furniture more efficiently. Tall pieces may be placed on the top shelf with no posts or shelves above them. At least two element grooves should be left between the floor of the kiln and the first shelf.

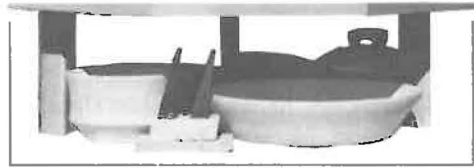

Small, light pieces of greenware can be placed directly on the brick bottom



Heating elements must be at a greater temperature than the rest of the kiln in order for heat to transfer throughout the chamber. Because of this, the zone immediately around the heating element will be considerably hotter, and ware should be placed at least one inch away from an element coil. Larger pieces requiring all of the kiln's firing capacity should be placed so that the projecting edges are between coils.

Each shelf may be supported by either 3 or 4 posts with the minimum spacing between not less than 2 1/2". Shelves must be stacked so that there is at least a row of heating elements between any two shelves. To achieve this minimum height between shelves you may wish to add a 1/2 inch post to a 2 inch post. Keeping the need for air circulation in mind, place the posts on the floor of the kiln as you are loading your ware. The posts used with each layer of ware should be at least one inch taller than the ware.

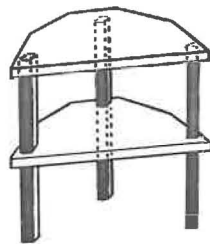

Correctly Positioned

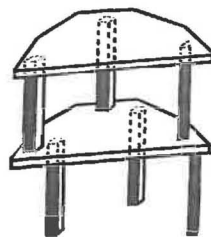

Incorrectly Positioned

If at all possible, posts should be placed so that there is an implied rest of one upon the other with shelves separating each layer. This will protect the shelves from breaking. As heavier, larger pieces are loaded in the top section of your kiln, the posts sitting one on top of the other will properly make the bottom of the kiln bear the full weight of the load.

FIRING

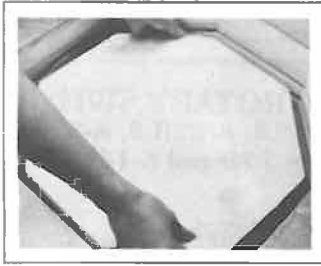

Place each shelf in the kiln by holding two edges and lowering it carefully so the sidewalls of the kiln will not be damaged. Be careful not to jar or shake the kiln after loading has started, as the ware or a shelf could be knocked over and broken. Shelves should be 1 inch to 2 inches smaller than the firing chamber of the kiln in which it is to be used, as well as loaded 1 inch above or below the refractory tube if your kiln is equipped with kiln-sitter.

(See page 11 for adjustment and operating instructions of kiln-sitter before you fire).

Always have at least one element groove between each shelf. Your heaviest pieces should be layered where they will receive the most element groove coverage. Make sure at least one element groove is between the top shelf and the top of your kiln.

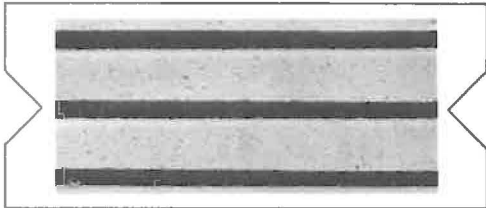

The most important item that goes in your kiln will be the pyrometric cones. We urge the use of at least one large pyrometric cone behind the peephole on the kiln's shelf, regardless of whether or not your kiln is equipped with kiln-sitter or limit timer. If you follow this suggestion of using large cones on the shelf to indicate the maturity of the ware, you will be rewarded by both beautiful ware and an increase in knowledge with each firing.

FIRST CONES - The first pyrometric cones should be placed in the bottom of your kiln, 3 inches directly behind the peepholes (to prevent cool air exposure) and completely visible through the peepholes. Use a short post, scrap of firebrick or modeled and fired clay pedestal to elevate the cones to correct height. Check the cone's position before placing the first shelf in your kiln.

SECOND CONES - The second cones should be placed on a shelf so that they may be seen through the next higher peephole from the bottom. If your kiln has a third peephole, cones may be positioned as previously explained.

Particular loading requirements for each type of ware are discussed in the following pages. Load accordingly, keeping these general points in mind.

Firing a piece of ware is the final step in making it a beautiful creation or a hopeless mess. It all depends on you, as there is no automatic device that can substitute for your personal attention to every firing.

Most ceramic bodies have only one exact point at which they will mature to their greatest degree of perfection. However, most of the ceramic bodies used in ceramics today have from one to two cones firing range for maturity in which satisfactory results can be obtained. In no way can we control or guarantee the kiln's turning off at just the right point. Only by using the proper cone for the ware being fired and watching it closely can you protect the ware and your kiln. The warranty on your kiln does not cover damage from overfiring, regardless of the circumstances involved. It is your responsibility to watch the cone at regular intervals and turn the kiln off as soon as the cone has bent.

Check the kiln frequently during the first few firings, and note the color inside the kiln. After a while you can learn to estimate, with considerable accuracy, the relationship the color has to pyrometric cones.

Allow kiln to cool to room temperature before opening lid. Cooling time is usually twice the firing time.

All A and B series kilns have 4-way rotary switch(es) except the A-11-6B which has a stepless control switch and the four extension collars, which have 3-way rotary switches. The switch(es) are manipulated to equalize the heat difference in the bottom and top of the kiln. To put more heat in the bottom of the kiln, heat is applied to the bottom section first, and for a longer period of time. The 4-way rotary switch is arranged internally to provide an easy way to accomplish this. Heating elements used with 4-way switches always work in pairs, and each element makes two or three complete turns around the kiln. Models having one 4-way switch have two elements, models with two 4-way switches have four elements, and models with three 4-way switches have six elements.

4-WAY ROTARY SWITCH

Switch on LOW position

The LOW heat position of the switch connects both the upper and lower element of each pair together so they produce only 1/4 their full heat. This position provides a means of limiting the rate of temperature increase in the early stages of firing.

A fairly slow, but even rate is extremely important in preventing breakage of the ware. Slow firing produces better quality and finer grained ware.

The best place to extend the time required to fire is at the lowest temperature, as the total firing time is controlled by the length of time the kiln switch is left on LOW.

SWITCH CONTROLS

Switch on MEDIUM position

The MEDIUM heat position should be used only for balancing the heat between the top and bottom of a one switch kiln, so that the temperatures will be equal when the firing is finished. In a two switch kiln, the MEDIUM position is for building up the temperature gradually through the middle range, but always in a sequence that will allow the operator to add more heat to the bottom of the kiln (the most difficult area to heat). Certain elements will show a bright red glow on MEDIUM. (see section on Switch Controls for explanation).

If bottom cone bends first, indicating that bottom of kiln is firing hotter than the top, leave the bottom switch on MEDIUM for 15 minutes longer on the next firing. If the top cone should bend first, turn the bottom switch from MEDIUM to HIGH 15 minutes sooner on the next firing.

Switch on HIGH position

The HIGH heat position equalizes the temperature throughout the kiln. When the switch is on HIGH, all elements controlled by the switch are on full power.

3-WAY ROTARY SWITCH

Switch on LOW position

The LOW heat position of the switch allows the element to produce only 1/4 its full heat, and provides a means of limiting the rate of temperature increase in the early stages of firing. In this position you can extend the time required to fire, since the total firing time is controlled by the length of time the switch is left on LOW.

Switch on HIGH position

The HIGH heat position equalizes the temperature throughout the collar. When the switch is on HIGH, the element controlled by the switch is on full power.

Since the 3-way rotary switch is used only on the extension collars that are added to kilns with 4-way rotary switch(es), the switching sequence will be different. Please refer to the Recommended Firing Schedule Poster as a guide for knowing when to advance the 3-way rotary switch.

STEPLESS CONTROL SWITCH

A stepless control switch controls the heat by cycling on and off. At the LOW setting, the kiln's heating element is on only 15% of the time. The higher the switch setting, the longer the element stays on. At the HIGH setting, the element remains on continuously.

TWO 4-WAY ROTARY SWITCH KILNS

A-23B-3, A-82B, A-82B-3, A-81B, A-88B, A-77B and A-15B

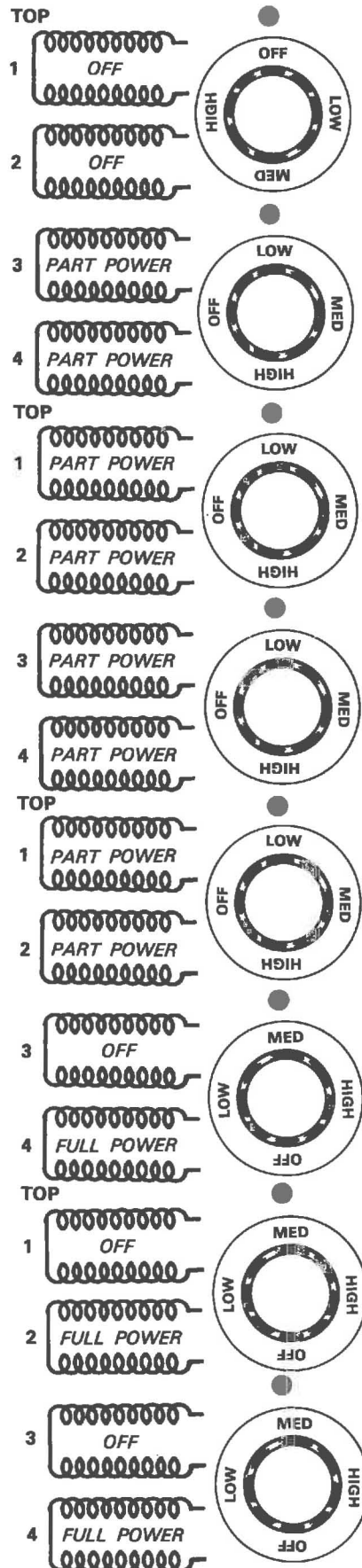

a. Top switch OFF, elements 1 & 2 off. Bottom switch on LOW, elements 3 & 4 glow dull red.
1/8 POWER

b. Top and bottom switches both on LOW. All elements glow dull red.
1/4 POWER

c. Top switch on LOW, elements 1 & 2 glow dull red. Bottom switch on MEDIUM, element 3 off and element 4 glows bright red.
3/8 POWER

d. Top & bottom switches on MEDIUM, elements 1 & 3 off, 2 & 4 glow bright red.
1/2 POWER

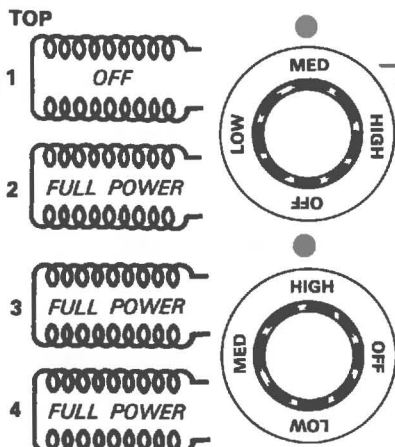

e. Top switch on MEDIUM, element 1 off, element 2 glows *bright red*. Bottom switch on HIGH, elements 3 & 4 glow *bright red*.
3/4 POWER

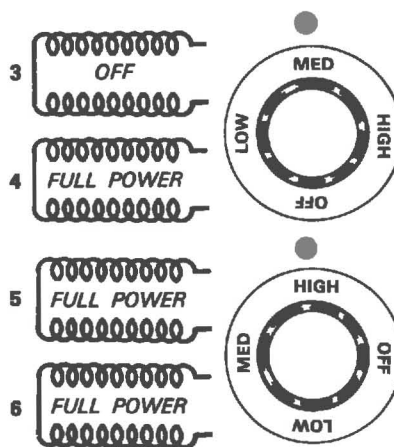

b. All switches on MEDIUM. Elements 1, 3 & 5 off. Elements 2, 4 & 6 glow *bright red*.
1/2 POWER

c. All switches on HIGH. All elements glow *bright red*.
FULL POWER

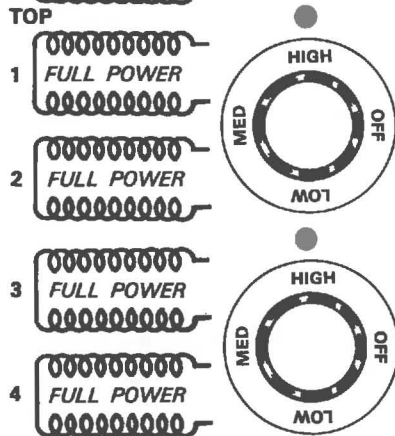

f. Both switches on HIGH. All elements glow *bright red*.
FULL POWER

ONE 3-WAY ROTARY SWITCH COLLARS AA-8B, AA-8B-3, AA-6B, and AA-6B-3

NOTE: These are 3-way rotary switches. To switch from LOW to HIGH the knob must be switched through OFF. If the knob is forced through the blank position the switch will break.

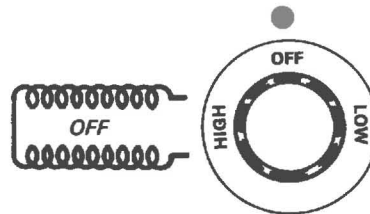

a. Switch on OFF. Element has no glow, but must be switched through this position.
0 POWER

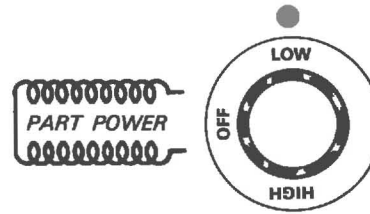

b. Switch on LOW. Element glows *dull red*.
1/4 POWER

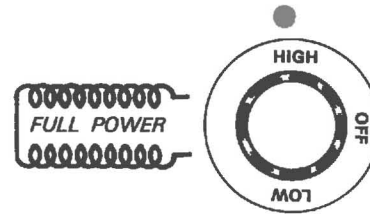

c. Switch on HIGH. Element glows *bright red*.
FULL POWER

ONE 4-WAY ROTARY SWITCH KILNS A-66B, A-66B-3, A-55B, A-11-9B and A-11-9B-3

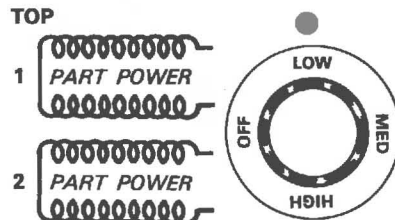

a. Switch on LOW. Both elements glow *dull red*.
1/4 POWER

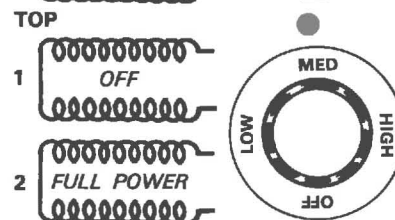

b. Switch on MEDIUM. Top element off, bottom elements glow *bright red*.
1/2 POWER

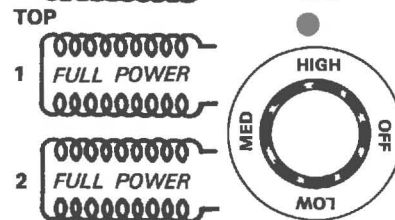

c. Switch on HIGH. Both elements glow *bright red*.
FULL POWER

STEPLESS CONTROL SWITCH KILN A-11-6B

The A-11-6B has a bimetallic timer that cycles on and off any percentage of the time from 15% to 100%. When the switch is turned to HIGH, the current flows continuously.

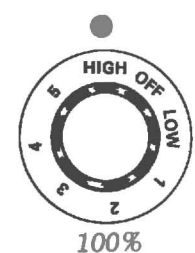
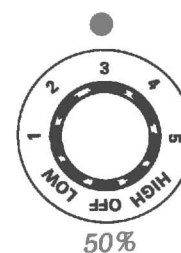
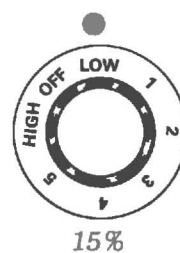

THREE 4-WAY ROTARY SWITCH KILNS A-24B, A-24B-3, A-28B-3, A-99B, A-100B with AA-10B

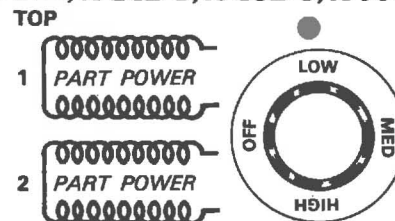

a. All switches on LOW. All elements glow *dull red*.
1/4 POWER

LOADING AND FIRING LOW-FIRE GREENWARE

Low-fire greenware refers to clay bodies with a usual firing range from cone 06 to 02 or any cone between 06 and 02. The greenware is often formed by being cast in a plaster mold, although the ware may be formed by hand building or draping.

The greenware must be bone dry before it is placed in your kiln. Otherwise, it will crack when fired or, in extreme cases, explode. Check for dryness by touching to cheek or against inside of wrist. Ware will be cold if not dry.

Low-fire greenware may be stacked so that it touches other greenware directly on shelves or your kiln's floor and without using kiln wash if it is being fired alone. You should plan on loading small, short pieces on the floor; however, large, flat pieces can go in first if placed on short posts so air can flow beneath the ware. Large, heavy pieces of greenware will fire best if placed across two half shelves positioned at an even height. For the most economical use of posts and kiln capacity, place ware of approximately the same height in each layer.

Ware should be fired in the position in which it will be used when finished, except for large pieces with flat, vertical surfaces. Wall plaques, clocks and the like should be fired flat to prevent warping. Pieces to be used together should be fired in place, such as a box with its lid, to ensure a good fit.

Low-fire greenware firing is simple and easy. Just be certain the greenware is fired to the pyrometric cone recommended by the clay supplier. If the greenware is not fired hot enough to reach the correct degree of maturity, moisture will be absorbed after the piece has been glaze fired and cause the glazed surface to crack. This defect in your ware is referred to as "crazing," and is most often due to underfired greenware. To help eliminate crazing, fire greenware at least one cone hotter than glaze, and even more if glaze can still be applied easily to the hard bisque. While glaze may be applied to greenware and fired once, we have never seen a superior piece of one-fire ceramics, and therefore do not recommend it.

The average cast piece is quite satisfactory if fired on a fast schedule such as the procedure shown in Paragon's Operating Instructions mounted on the side of your kiln. However, slow firing of heavy pieces reduces danger of breakage and in both heavy and light pieces produces better quality and finer grained ware. Slow firing also tends to reduce crazing.

Make sure the pyrometric cone is clearly visible behind each peephole before firing so you can check on the maturity of your ware during operation. Do not put all peephole plugs in the kiln until the switch(es) are on HIGH. Refer to the enclosed Recommended Firing Schedule Poster for superior, controlled firing. Allow kiln to cool to room temperature before opening lid.



Two sizes of greenware loaded directly on kiln's floor. Note different sizes of posts and use of two large pyrometric cones behind the peephole.



Shelves placed on posts and ware loaded. Note ware to be used together should be fired together in the greenware firing.

Large, flat pieces may be placed on kiln's floor, if short posts are used to allow heat circulation.



Large, heavy pieces of greenware will fire best if placed across two half shelves positioned at an even height.

LOADING AND FIRING PORCELAIN GREENWARE

Porcelain greenware refers to clay bodies which may have a maturity point of one cone between cones 4 to 10. Porcelain is vitreous and the white color will usually show the shadow of the hand if held between the eyes and a strong light.

Loading porcelain greenware and loading glazed ware are very similar, since both will stick to anything while being fired. Greenware must be completely dry before being fired, including the joints on pieces that are attached. If a piece is broken while placing it in the kiln, mend the break but do not attempt to fire it until the mended area is also bone dry. Damp greenware or damp mended areas will cause bumps on the surface of the fired ware.

Stilts *cannot* be used to support porcelain greenware as they will become embedded in the porcelain when heated to high temperatures. To protect porcelain from sticking to shelves or kiln floor, apply a covering coat of all-purpose, high fire, kiln wash to the shelf tops and brick bottom, then place your ware directly on the kiln washed surfaces. *NEVER use ceramic kiln wash in a kiln that will ever be fired to porcelain temperatures, as the ceramic kiln wash will harden at high temperatures and be impossible to remove.*

Pieces of ware that are to be used together must be fired together, such as a box and its lid. Powdered silica can be used to protect these pieces during firing. Application of dry powdered all-purpose, high-fire, kiln wash is another way to prevent lid from sticking to box. Wet kiln wash would be too difficult to remove from the box lid after the piece is fired.

Pieces likely to warp in firing should be supported by rolls of porcelain clay shaped to fit the objects at points of strain. Apply dry silica or high fire kiln wash to points of contact to prevent the rolls from sticking to the piece. Be sure the support rolls have dried out completely before firing.

Since a kiln is slightly hotter near its sidewalls, the side of the ware next to these walls will tend to shrink more than the opposite side. This may be used to an advantage with porcelain figurines that tend to warp during firing, as the inclined side of the figure can be turned away from the elements allowing the heat to help hold the piece straight.

Cones mounted in plaques are even more important in porcelain firing than ceramic firing, because they turn quite rapidly when maturity is reached. It is advisable to use two cones at each peephole, one as a warning cone and the other to control firing. *For example: if you are firing porcelain bisque to cone 5, place both cone 4 and cone 5 in the kiln, slightly offset from each other so that both may be seen. When cone 4 begins to bend, check the kiln every 3 minutes until cone 5 bends. Then turn your kiln off immediately.* The cost of the extra cone will be repaid many times over in better ware.



High fire kiln wash will keep porcelain greenware that must be fired together from sticking. The kiln wash should be dry; wet kiln wash is difficult to remove after firing.

Leave the peephole plugs out and vent the lid until all smoke and odor are gone when you fire draped figurines.

Porcelain greenware should always be fired slowly. Use the enclosed Recommended Firing Schedule Poster as a guide for obtaining the best switching positions for the type of porcelain you are firing. The kiln will not overfire with all switches on LOW position, since there is not enough power to raise it to more than approximately 1,000° F. Like all other firings, do not remove the ware from the kiln until it has cooled enough to handle with your bare hands. As a rule, it takes twice the time to cool the kiln, as to heat the kiln. Do not open until kiln has reached room temperature.

LOADING AND FIRING PORCELAIN GLAZE



Each piece of porcelain glaze is "dry footed" before being placed directly on a kiln washed shelf or brick bottom. Pieces that were fired together in the greenware firing cannot be fired together in the glaze firing, and it is not necessary to support the ware with ceramic fiber or rolls of porcelain clay. The use of pyrometric cones is very important!

Loading porcelain glaze is similar to loading porcelain greenware. Lightweight ware and small pieces should be placed on the bottom of the kiln no closer than 3/4 inch to the sidewalls for best circulation of air and distribution of heat.

Porcelain pieces which have been fired together in the greenware firing cannot be fired together in the glaze firing. Both pieces must be "dry footed" to prevent sticking to each other. As shrinkage has already occurred in the greenware firing, the piece will still fit even when fired separately in the porcelain glaze firing. Stilts must not be used to support porcelain, since the porcelain will soften during firing and cause the stilts to become embedded. Before you load your ware, make sure you have applied a good coat of all-purpose, high fire, kiln wash to the kiln floor and tops of shelves.

Like firing porcelain greenware, it is advisable to use two large pyrometric cones behind each peephole when you fire porcelain glaze. One of the cones should be used as a warning cone and the other to control firing.

Follow the Recommended Firing Schedule Poster to fire both porcelain greenware and porcelain glaze. The LOW heat period can be shortened by two or three hours for glaze firing. If a piece of ware had to be supported in the bisque fire, it will stand alone in the glaze fire. The lower temperature will prevent sagging.

Allow kiln to cool to room temperature before opening lid. Cooling time is usually twice the firing time.



Glazed porcelain pieces are never supported by stilts. Instead, each piece must be "dry footed". A sponge is used in this example to remove the glaze from the bottom of the piece.

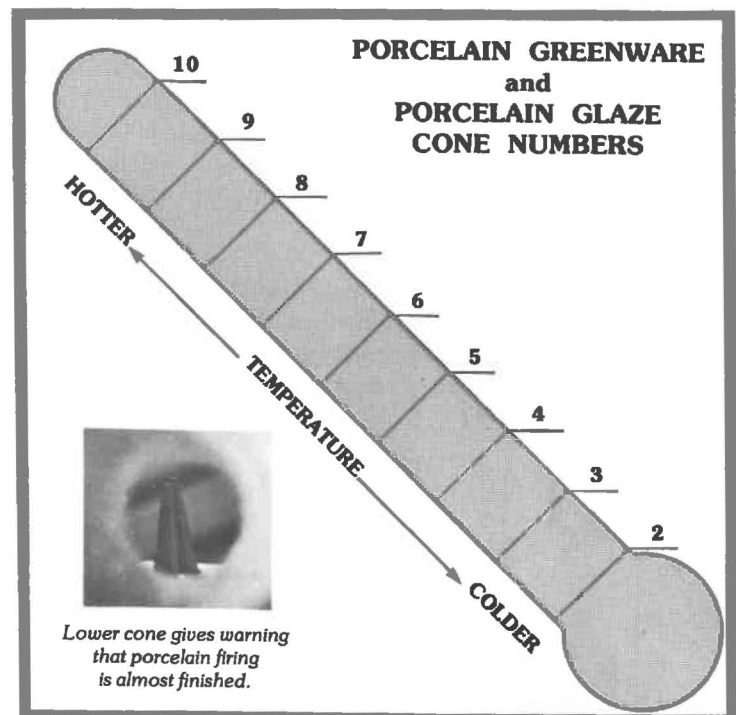

LOADING AND FIRING OVERGLAZE

Overglaze is a general term which indicates all forms of decoration which are usually applied over a fired glazed surface or a polished porcelain bisque surface. Overglazes include china paints, gold, luster, etc., usually having a firing range from 022 to 014.

Loading the kiln in the same manner used to load ceramic glaze, overglazed ware must be prevented from sticking by the use of stilts and must not touch other ware. It must be completely dry before firing to prevent poor finish results.

China paints must not be applied heavily, as cracking or peeling will occur. Apply several light coats, firing between each, until the desired shade is obtained. Since all china paint colors do not reach maximum color and brilliancy at the same temperature even when fired on the same ware, it is important to know which colors you should fire first at higher temperatures to prevent burning out the original colors in later firings. *For example: Reds mature at a lower temperature than other colors and are fired after the other colors have been fired. Reds and yellows should not be fired side by side. Colors mature at a lower temperature on ceramic pieces than on porcelain or hard china.* Check the overglaze manufacturer's literature for information on which cone to use with each color and type of ware.

Plates fire better when supported by a plate holder or placed on edge to permit heating. If fired on edge, plates may be supported at the bottom with large spur stilts, which may also be used to separate adjoining plates. Tall posts can be used to prevent plates from touching the kiln wall.

The kiln must be vented with all peephole plugs out until china paint oil and other organic materials have vanished. This should be done while the kiln is at a low temperature, but the length of time required to burn out the oils will vary with the amount of decoration on the ware. The kiln may be left on LOW for as long as necessary for all odors of the oils to disappear, at which time the kiln's sidewalls will have a dark red appearance. Then put the peephole plugs in place and close the lid.

Watch the cone behind each peephole closely, as even a small amount of overfiring will cause overglaze colors to fade. Turn the kiln off *immediately* when the pyrometric cone tip is even with the cone base.



PROP-R-VENT engaged in its extended position for the venting of lusters and other overglazes.



China painted plates stacked on edge and separated by stilts.

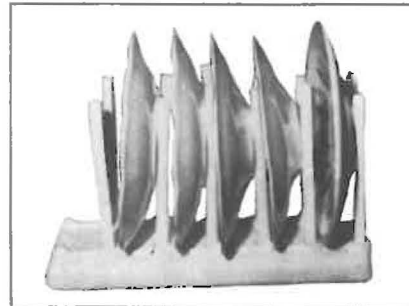

Plateholders ensure even firing of china painted plates.

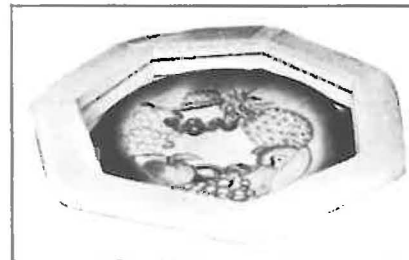

Position plates between elements for proper heat distribution.

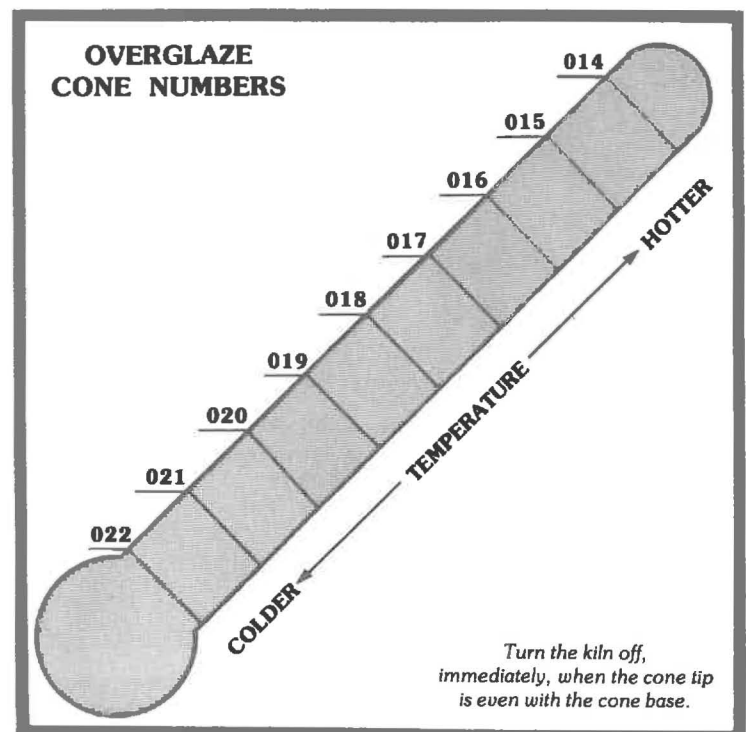

GREENWARE OR GLAZE

Stoneware is made from vitrifiable clays which have a firing range from cone 2 to cone 10. It has a wide range of colors and textures and is popular with the potter, because of its excellent throwing qualities. Usually the greenware is fired below maturity and on the second firing the clay and glaze mature together to form integrated body-glaze surfaces.

Like porcelain greenware, stoneware objects are placed directly upon the kiln washed shelves in the greenware firing. Distribute the load with small items on bottom of firing chamber and large, heavy pieces on even, half shelves for good air circulation.

Glazed stoneware must not touch any other ware and must be dry footed before being placed on a kiln washed shelf or kiln bottom. Never stilt stoneware during either firing.

Keep an accurate firing on the sheet provided with this manual until you know exactly how to time the switching. A kitchen timer or alarm clock can be used to remind you to change switches. A Recommended Firing Schedule Poster has also been enclosed as a guide to get you started; however, it is up to you to work out the exact timing for your particular installation and clay. Never leave your kiln unattended for more than a few minutes on the first firing, as your kiln may fire in as little as half the average time shown on the chart.

Glazed stoneware must not touch any other piece on a kiln washed shelf or the brick bottom.



"Dry Footing" stoneware with sponge.

Large, heavy pieces of glazed stoneware will fire best if placed across two half shelves positioned at an even height.



PAINTING

China painting antique glass lamp shades and decorating old bottles are two of the most popular forms of painting on glass. Use the same procedure for loading and firing this type ware as you would use for overglaze. Cone 022, the lowest cone, is used for firing. Turn the kiln off as soon as the cone starts to bend (*do not wait for a full bend*) and open the kiln 3 or 4 inches and rest on Prop-R-Vent immediately to prevent further heat absorption. Do not open the lid completely until the kiln has cooled to room temperature.

The trick in firing this type of glass painting is to have it cool quickly. This keeps it from warping or melting, but even with forced cooling some shapes must be supported completely during firing. Supports may be made from castable insulating material or by shaping an insulating firebrick to fit the piece.

SAGGING

Glass sagging refers to the technique of a plate of glass being placed on top of a ceramic bisque glass sagging mold, well coated with whiting, and being fired. During the firing the glass sags into the ceramic bisque sagging mold and takes the mold's shape.

This is not a mysterious or complicated operation. Molds are made of terra cotta or other low fire clay and you can make your own or buy them. There are many different types of glass that can be placed on top of the coated mold and decorated in hundreds of different ways.

The length of firing time for glass sagging is less than ceramics. Place an 015 and 014 cone in your kiln and fire until the 014 cone has bent halfway. Then, position the kiln switch on LOW heat for 1 hour. Manually turn kiln off. With kiln lid closed, cool for at least 8 hours before opening. *The danger in glass sagging is fast cooling rather than fast firing.*

Your dealer may be able to give you additional information or you may wish to read one of the many excellent books on glass sagging.

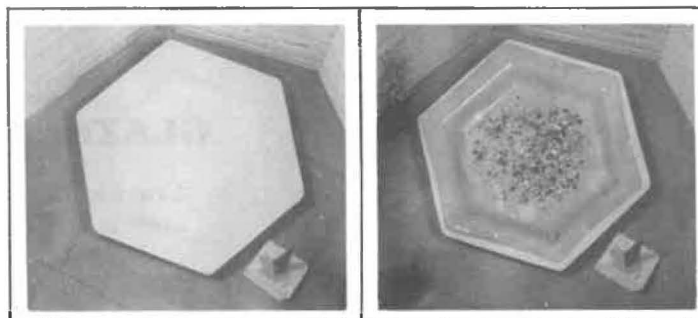

Decorated piece of glass will be put on top of glass sagging mold.

Piece of glass that has sagged. Note that it has shrunk inside mold.

Imperfection is recognized any time a piece does not turn out as expected. If you unload your kiln only to find disappointing results in a particular piece of ware, you should justify your dismay with reason. Normally, defective pieces are caused by one of the reasons listed in this section.

BISQUE

Warped ware can be caused by distorting upon removal of the piece from the mold, being fired too close to the elements or firing a piece in an unnatural position. To prevent porcelain cups (or bowls, etc.) from warping when firing the greenware, edge the top of a cup with pinches of dry silica (flint) or *DRY* all-purpose, high fire, kiln wash and place a second cup on top of the first cup, lip to lip, with handles going in opposite directions. Porcelain greenware plates must be fired in plate saggars to prevent warping during firing.

Sagging ware is usually the result of overfiring. Porcelain objects are subject to sagging if the design is not properly supported during firing.

GLAZE

Crazing is usually caused by underfired bisque. Bisque should be fired to the highest temperature at which it will still take glaze. Crazed ware may be refired to the proper cone. *CAUTION: China paints and other overglazes will fade when fired to 06.*

Glaze too thin in spots can be caused by uneven glazing or a "hard spot" on the bisque. Ceramic glaze should be applied in flowing coats; first in one direction and the next coat in an opposite direction (horizontal, then vertical or vice-versa). Allow to dry between each coat. Some glazes may require twice the recommended coats, because of thin application. Porcelain glaze should be sprayed or a brush-on type used. "Hard spots" can be caused by the first place the poured slip touches the mold. Heating in an oven to approximately 120° F. will help in applying glaze to hard bisque.

Crazing immediately on removing from the kiln can be caused by not firing the ware hot enough. Refire to the proper cone. Crazing in spots can be caused by not having mixed the glaze thoroughly before using.

Black specks in the ware are usually caused by organic materials not completely burned out in the bisque firing. This works its way to the surface during the glaze firing.

Pinholes and bubbles in glaze or glazed ware can be caused by too heavy a glaze application, by severe underfiring or by dust on the bisque. Damp bisque can reduce the number of air pockets and pinholes that may form when glaze dries too quickly. Clean bisque with tap water or use base coat of glaze thinned, 3 parts glaze to 1 part water immediately before applying glaze in the usual manner to the bisque.

Poor color in colored glazes can be caused by too thin an application, placing ware too close to an element or to other glazed ware which may be incompatible, insufficient venting during the early stages of firing or overfiring glazes in the red family.

Light edges on dark glass glazed pieces may be caused by the flow of the glaze away from the edges in two directions. Try an extra coat of glaze on the edges or apply thin coat of underglaze in following manner: Mix 1 part water with 2 parts of suitable dark or black underglaze and brush a thin wash coat of the underglaze over the bisque ware. Then, immediately apply the first regular coat of full strength glaze. Allow to thoroughly dry before applying second coat of glaze. Continue with number of coats recommended by the manufacturer.

Sagging glaze is usually caused by applying too much glaze on a vertical surface causing the glaze to actually sag when fired.

Crawling or bare spots on a fired piece can be caused by applying the glaze too heavily. Oil from your skin that gets on the greenware before it is fired can also cause this. Another cause may be hard spots from too much polishing of your greenware when sponging. A few drops of vinegar in your sponging water will help alleviate this problem. Crawling may be corrected by applying more glaze to these spots and refiring.

UNDERGLAZE

Streaks in underglaze are usually caused by not applying enough coats to the greenware. After a piece has been decorated with underglaze and fired, you may check it for streaks by submerging it in water and immediately removing it. The piece will appear glossy, just as if it has been glazed, and streaks and thin spots will show up. The weak spots can be touched up and refired. Be sure that the underglaze has been fired before putting it under water.

Underglaze colors may be applied over unfired matte or texture glazes which do not flow for interesting designs.

OVERGLAZE

Breaking in overglaze firing can be caused by poorly fired bisque. A slow bisque fire is always better for ware which is to be china painted. The greenware should be completely dry *before* being placed in the kiln. Standing plates on edge or using a plate holder gives good heat circulation and will help in preventing plate breakage.

Purple spots in gold are usually due to a thin application of gold or too much thinner. If gold is applied accidentally to an area it will show purple after being fired unless cleaned with a good gold remover.

Broken lines in gold can be caused by overfiring or too heavy an application. However, this is very attractive when gold is crackled over a dark color of fired glaze.

Peeling china paint can be caused by the paint being applied too heavily.

Loss of color in china painting is usually a result of overfiring or thinning your paint with too much medium when applying.

Faded colors in overglaze decals are a result of either underfiring or overfiring. If pinks and reds are drab, refire to a hotter cone. When used with a china paint background, apply and fire the decals first, then china paint and fire again. *Check the recommendations of decal supplier.* If decal was underfired, refire to proper firing cone. If decal was overfired, the design may be repainted in china paints and refired.

Weakening of luster colors can be caused by overfiring.

White spots in lusters or metals can be caused by moisture on the ware before it was placed in the kiln or from having been fired at the same time as other overglazes. *Apply lusters only on a dry day.*

Powdering of luster colors can be caused by too heavy an application.

PORCELAIN

Bumps in porcelain are usually caused by wet greenware and overfired porcelain bisque.

Lack of translucency in porcelain can be caused by the ware being poured too thick and underfired.

Cracks in porcelain bisque are often the result of a strain on the greenware while drying. *Do not force dry greenware.* Cracks may be mended with one of the new "magic menders" available from your supplier.

Holes in lace or fabric which appear after firing can be caused by inadequate application of the slip. Wash the fabric thoroughly before dipping it into the slip. Apply enough slip to the fabric so the clay will be strong enough to hold its own weight. The fabric must burn out before the clay matures, leaving only the clay shell, which must be strong enough to support its own weight.

USING YOUR KILN

-
- DO** place the kiln on stand provided - no substitute.
 - DO** locate your kiln at least 12 inches away from any wall or combustible surface, and keep unsupervised children away.
 - DO** check to be sure all switch(es) are in OFF position before you plug in your kiln.
 - DO** raise lid and engage lock-in lid support.
 - DO** coat tops of shelves and bottom of kiln with all-purpose, high fire, kiln wash.
 - DO** *always* place large pyrometric cones on a shelf behind each peephole *every* time you fire.
 - DO** make sure your cones are visible through a peephole before each firing.
 - DO** release lock-in lid support and lower lid to Prop-R-Vent.
 - DO** use dark glasses (sun shades) if large cones are difficult to see at high temperatures.
 - DO** turn kiln switch(es) to OFF position, *immediately*, if you cannot see the cones.
 - DO** check your circuit breakers or fuses anytime the kiln stops firing.
 - DO** use *new* cones if ware must be fired again for any reason.
 - DO** call your dealer if you have trouble firing your kiln.
 - DO** follow your kiln-sitter and/or limit timer instructions carefully, if installed. Neither operates as a guarantee against overfiring - *only a convenience!*
 - DO** fire red or yellow glazes separately.
 - DO** use only tested, approved and properly labeled glazes for food and drink containers.

-
- DO NOT** install kiln closer than 12 inches from any wall or combustible surface.
 - DO NOT** fire your kiln until you have checked for bulging (sagging) elements and reseated them in their recessed grooves.
 - DO NOT** exceed the maximum temperature shown on kiln's nameplate.
 - DO NOT** use kiln for purposes other than firing ceramic materials.
 - DO NOT** overload your electrical circuits.
 - DO NOT** attach an extension cord to your kiln's power supply cord.
 - DO NOT** allow kiln's power supply cord to come into contact with side of kiln.
 - DO NOT** touch hot sides of kiln or lid handle.
 - DO NOT** fire by time or temperature alone - *always use pyrometric cones!*
 - DO NOT** put all peephole plugs in the kiln until all vapor has left the kiln.
 - DO NOT** use your firing controls or Recommended Firing Schedule Poster as set rules for all types of firing.
 - DO NOT** open your kiln when it is at high temperatures.
 - DO NOT** open kiln lid until kiln has cooled (8 to 12 hours) and all switch(es) are turned to OFF position.
 - DO NOT** let glaze or kiln wash touch the heating elements.
 - DO NOT** touch heating elements with *anything*; disconnect kiln before servicing.
 - DO NOT** use your kiln-sitter and/or limit timer without reading and studying your instructions carefully.
 - DO NOT** set porcelain or stoneware on stilts.
 - DO NOT** make any variations in glaze manufacturer's instructions when using glaze for food or drink containers.

VOCABULARY

BISQUE

Fired unglazed clay.

CLAY

As used in ceramics, it is a blend of clays and minerals.

CONE, PYROMETRIC

A small pyramid of ceramic materials which will react to the effect of time, temperature and atmospheric condition inside the kiln in the same way as ceramic ware.

CRAZING

Hairline cracks in glazed ware. Most common cause is underfired bisque.

DECAL

A design or picture printed in overglaze or underglaze colors on a protective coating. The decal is slipped from the paper backing on to the appropriate ware and fired for permanency.

DRY FOOTING

Removing all glaze from the bottom of ware before firing to eliminate need of stilting.

FIRING

Maturing ceramic products by the work of temperature, time and atmospheric condition inside the kiln.

FIRING CHAMBER

The inside of the kiln which holds the load of ware being fired.

FOOT

A small ridge at the base of a piece of ware.

GLAZE

A liquid composed of glass particles applied to ceramic ware.

GREENWARE

Unfired clay objects.

HIGH FIRED

Ceramic bodies fired to cone 4 or higher, such as porcelain.

KILN WASH

A powder mixed with water and brushed on top of shelves and bottom of kiln's firing chamber as protection from drops of fired glaze. May be made of minerals having high fire capabilities, but sometimes made of low fire materials.

KILN-SITTER

A cone activated, mechanical device to shut-off the kiln at the proper temperature.

LUSTER

An iridescent overglaze, sometimes metallic.

MATURING POINT

The amount of "heat-work" needed to correctly mature clay or glaze. This is usually measured by the 6 o'clock bend of a large

pyrometric cone placed on a kiln shelf beside the ware being fired.

OVERGLAZES

China paints, lusters, gold, etc., usually used over a fired glaze but may also be applied on polished porcelain bisque and fired for permanency.

PLASTER - (PLASTER of PARIS)

A white powder used for making ceramic molds.

PORCELAIN

A vitrified, translucent ceramic ware.

POROSITY

A measurement of the amount of water a fired object will absorb because of being porous.

PYROMETER

An instrument for measuring temperature.

SILICA - (FLINT)

A mineral which will not harden at a very high firing temperature, used for separating porcelain greenware during firing.

SLIP

A liquid clay used in making ceramic objects by casting.

STILTS

Small clay or metal tipped supports used to prevent glazed objects from sticking to the kiln or shelf.

STONEWARE

A vitreous ceramic body usually made from native clays.

TERRA COTTA

A natural clay which may have grog added. Usually low firing and popular for sculptured objects.

THERMAL SHOCK

Stress caused by sudden changes in the temperature of ceramic ware; can cause cracks or breaks.

THERMOCOUPLE

The measuring unit of a pyrometer which is inserted into the kiln's firing chamber.

TRANSLUCENT

The quality of a piece of porcelain which permits the passage of light, but diffuses it.

UNDERGLAZE

A decoration applied to greenware or bisque, usually applied under the glaze.

VENTING

Allowing air to come into the kiln and vapor and gases to escape.

VITRIFY

To change into a glassy or a non-porous state by heat and fusion.

ELEMENT MAINTENANCE

The elements in your Paragon kiln will last for many years of normal use. A properly designed element never "burns out." With time, however, the element will gradually reduce the power it draws from the electric power, finally reaching a point where it will not develop enough heat to bend the cone. Elements should be replaced when firing time becomes excessive.

High temperature elements are damaged by contact with silica or silica bearing compounds. Glaze and some types of kiln wash contain large amounts of silica, and you must be very careful to prevent either from coming into contact with an element. If silica touches the elements it causes "burn out" at the point of contact. This type of element failure is not covered by warranty.

Additionally, reduction firing which removes the oxygen from your kiln will ruin your elements. The elements are protected by a coating of oxidation which reduction firing destroys. Reduction is performed at your own risk and damaged elements will not be replaced by warranty.

Paragon elements are not fastened in the grooves mechanically, as any fastening would cause a "hot spot" which would shorten the life of the element. If you seat the elements properly before firing the kiln for the first time and follow the recommended tempering procedure, you will probably have little or no trouble in the future. Should the elements start to bulge out of the grooves, they must be reseated immediately. To reseat an element, follow these simple instructions.

RESEATING AN ELEMENT

1. Turn the kiln switch to HIGH and allow the elements to heat until they show a dull red glow, then turn off the switch and **UNPLUG** the kiln. (A small blow torch may also be used to heat a section of element).

2. With a pair of long nosed pliers (dime store quality will work fine) shrink the bulging portion of the element by pressing the individual turns in the coils together slightly. Take a little from each turn so that no two turns will be pressed tightly enough to touch.

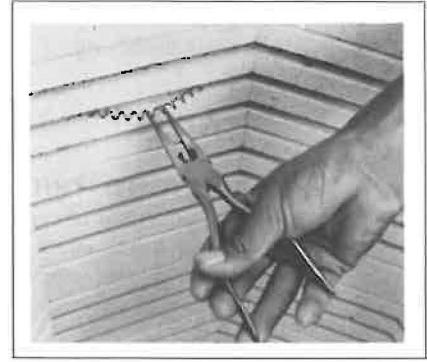

3. As the element shrinks, work it back toward the groove and into place. Work rapidly, and at the first sign of stiffness in the coils, stop bending and reheat the kiln. The elements do not have to be red to be bent safely, as the stiffening can be felt through the pliers.



4. To lengthen the element to fit into the corners, reverse the above procedure and expand the distance between coils by use of snap-ring pliers. Use caution, as your warranty covers only elements that fail in service under normal use, and not from being broken while cold.

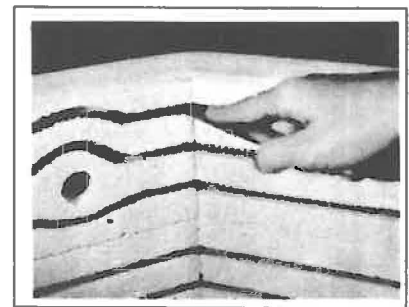

5. When you have the coils positioned above the dropped recess in the grooves, reheat the kiln, turn off the switch, **UNPLUG** the kiln, and run a blunt kitchen knife around the elements to seat them into grooves and make sure they fit all the way back into each corner.

6. Fire the kiln to cone 4 or 5 to soften the elements completely.

BULGING ELEMENT REPAIR AND PREVENTION

All heating element wires change in length with use. This is an inherent characteristic that metallurgical science has never found a way to control. This change can cause elements to shrink away from the corners and bulge outside the grooves into the kiln if preventive maintenance is not performed.

Paragon A and B-series kilns are equipped with alloy wire to withstand high temperature firing necessary to fire porcelain. The alloy becomes quite soft at maximum temperature and will not support its own weight. This softening of the wire enables the coils to conform to the grooves each time porcelain is fired, so bulging is no problem if you fire porcelain occasionally.

If the kiln is never fired hotter than cone 05, the element never becomes soft enough to conform to the grooves so bulging may occur. The elements are not mechanically fastened at the factory, as this tends to create a "hot spot" at the point of contact between the element and the fastener, and also causes the fastener to slightly embed in the element at porcelain temperatures. The advantage of longer element life, gained by free element installation, outweighs the inconvenience of occasional element maintenance.

Elements may be mechanically fastened in kilns which are seldom or never fired to porcelain temperatures without serious effect on element life.

SECTIONAL VIEW
FROM END OF
WALL BRICK

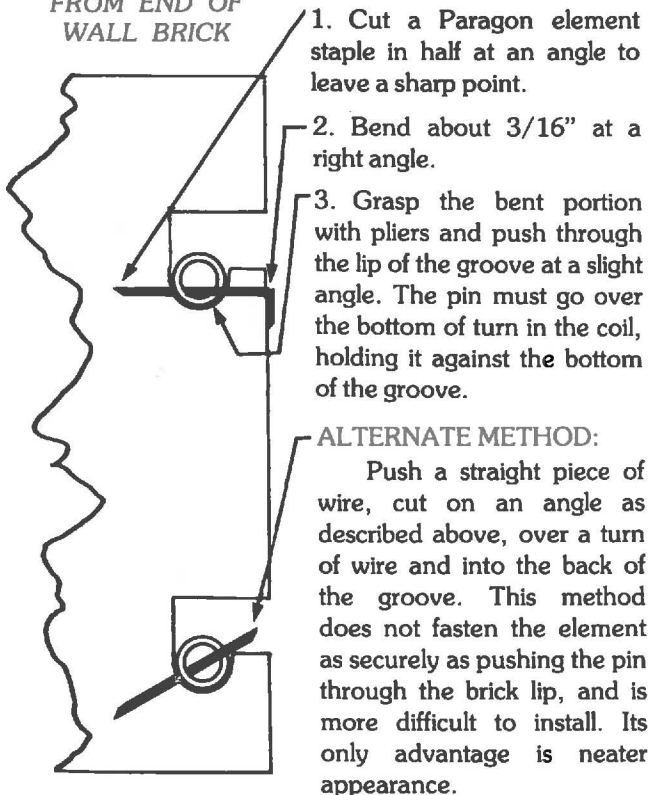

No mechanical skill is necessary to install Paragon replacement elements, only long-nose pliers and a screwdriver. However, your local Paragon dealer will install the element for you at a reasonable charge. If you do not have a local dealer, see your appliance shop repairman. He is more experienced in servicing heating devices than an electrician and is usually cheaper. Also, many materials used by electricians are not suitable for high temperature heating appliances.

Paragon replacement elements are formed to the shape of the kiln. However, a little stretching or compressing may be necessary for a perfect fit. It is safe to bend and stretch new elements before they have been fired, but once heated to high temperatures and allowed to cool, elements become brittle and will break.

1. **UNPLUG** or disconnect the kiln and allow to cool to room temperature.
2. Remove screws on each side of switch box and let box hang by switch-to-element lead wires.
3. Remove the screws in the element connectors that hold the switch-to-element lead wires to the element you are replacing.

4. On the same connectors, loosen the screws that hold the element and throw old connectors away. Always use the new connectors furnished with the new element.

5. Remove and save the porcelain insulators that were under element connectors.



6. Remove the old element carefully to prevent breaking the lip of the element grooves. (If one should break, you can repair the brick with repair cement after the new element is installed.)

If the old element burned out due to contact with foreign materials, there will probably be a melted, glazed spot in the element groove. Glazed spots left in the grooves may ruin the new element, so dig out any of these spots. The small hole left in the groove will not damage the new element. Small pieces of firebrick in the grooves should be removed with a dry paint brush or vacuum cleaner.

7. Protect the new element from accidentally coming in contact with kiln wash by placing newspaper on the kiln bottom. To keep from tangling up the element, keep it on the top rim of the kiln's sidewall when you feed it into the grooves. (If you place element in bottom of kiln, element will tangle up.) Also, arrange element so you're feeding the bottom loop first instead of the top one.

8. Thread the new element into the upper element hole. To guide the element through, you can look into the hole where the porcelain insulator goes. (Don't let the element hit your eye!) Or you can use the twisted end of the old element to thread the new element into the holes. To do this, insert the end of the old element into the hole where the porcelain insulator fits until the element appears in the firing chamber. Press the end of the new element against the end of the old one and push new element all the way through.

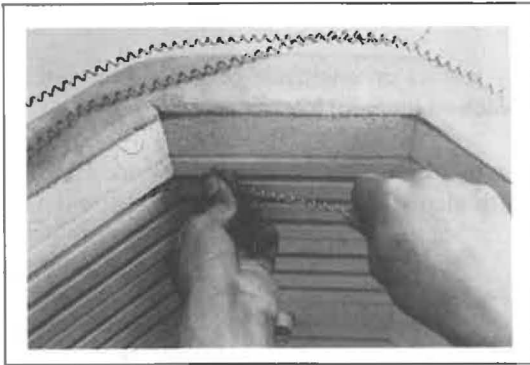

9. The element is bent slightly where it fits into each fire-brick corner. The bend must fit all the way into the back of each corner. As you feed the element, hold it with both hands in such a way that you are applying a constant pressure that pushes the element into the corners. If you let go before element is completely threaded, it will spring back out of the corners.

After the first element bend is in its corner, do the next corner. If the next element bend will not reach the next corner, gently stretch that section of element with your hands to make the next bend reach its corner. If the element is too long between bends, let that section of element curve out of the groove. Then continue threading the element into the other corners. When element is completely installed, go back to the section that was too long. Compress coils with long-nose pliers until the element fits into its groove. No two coils should be compressed tightly enough to touch.



Remember, if you do not push the element fully to the back side of each corner, the element will not stay in the grooves when fired!



10. Press element down into the lower part of the groove with a plastic comb or wooden tongue depressor.

11. Reinstall the porcelain insulators. Push them flush against the heat shield. They protect element from contact with case and heat shield, so they *must not* work their way out after the element connector is tightened into place.

12. Sandpaper the eyelet of the switch-to-element lead wires until bright and clean of all oxidation. (Install new lead wires if insulation on old ones is brittle.) Use the brass screw to connect lead wire eyelets to the new element connectors. Before tightening screw, adjust eyelet to where it will be tilted away from heat shield when connector is attached to element. Then hold connector with pliers and tighten brass screw securely with screwdriver.

13. Pull end of element tight and install new element connectors even against porcelain insulators to prevent insulators from slipping away from brick wall.

Use stainless screw in the element connector to hold the element. (The brass screw holds the lead wire eyelet.) Hold connector with pliers as you tighten the screw with a screwdriver. Tighten the screw until it squeaks.

14. Cut off twisted end of element even with side of element connectors. Leaving the excess element sticking out past element connector could ruin your new element! (The element could short against something in the switch box.)



15. As the switch box is moved back into place, check to see that no wire touches an element connector. Wires and wire nuts must also not touch kiln's case inside the switch box. **Wires and wire nuts will burn if they touch the case or element connectors.** Replace screws in switch box and tighten into place.

Test the element before loading kiln for firing. Plug in kiln and turn the switch to HIGH. Watch the element. It should come up to a dull red color over a period of several minutes for most models and never less than 10 to 15 seconds.

LID MAINTENANCE

Since your Paragon kiln lid is specially cut and formed with band reinforcement and refractory coating of its interior, chips in the brick are unusual if the lid is properly treated. Should chips appear in the lid, however, they should be repaired to keep them from becoming larger. Very small chips may be filled with Paragon Kiln Coating and Repair Cement.

SMALL CHIP REPAIR

1. Clean loose particles and dust from chip.
2. Dampen area with brush dipped in water.
3. Work cement well into pores.
4. Fill the area and evenly smooth surface of lid.

LARGE CHIP REPAIR

Do not use repair cement on large chips, because expansion of cement differs from expansion of the brick and it will break out when fired.

However, larger chips can be sealed with a very thin coat of repair cement and left unfilled. This type of temporary repair will prevent further damage, and does not harm the operation of the kiln in any way.

To permanently repair large chips or a broken edge of kiln's lid, remove lid from kiln as shown at lower right of this page, then follow these steps:

1. Trim damaged area with hacksaw blade and trace area on piece of paper as pattern.

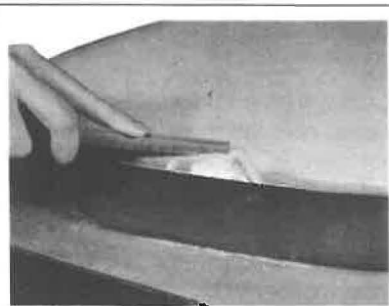

2. Trace pattern on new brick and cut new piece to replace damaged area.

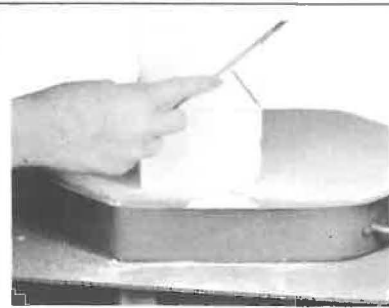

3. Apply liberal coating of repair cement to new brick and damaged area.

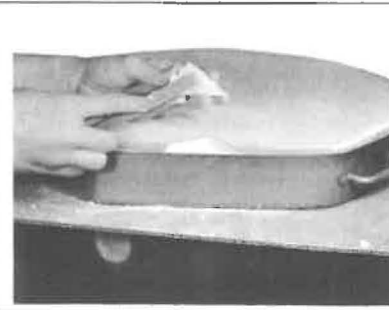

4. Press the new piece firmly into place, working rapidly before the cement dries. Scrape off excess cement.

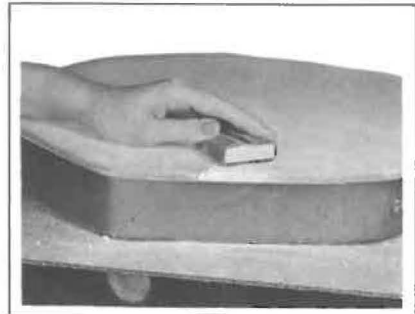

5. Let dry overnight, then sandpaper level and smooth.

6. Clean off all dust with whisk broom and apply a very thin wash coat of cement. With a soft cloth immediately remove all of the cement coating possible.



While it may seem that the thin wash coat has disappeared after the kiln is fired, you have actually left the inside surface of the lid with a hard, dust-proof coating.

BOTTOM MAINTENANCE

The bottom of your kiln should be covered with all-purpose, high fire, kiln wash at all times, because glaze may drip from your ware during firing and accumulate on brick floor. When this happens, the glaze should be scraped off and high fire, kiln wash applied to the spots.

Hairline cracks are a natural characteristic of insulating firebrick and are a result of the expansion and contraction of the insulating brick during each firing. Do not be concerned with these as they close tightly when the brick expands when heated. This expansion and contraction during firing is absolutely necessary for the long life of your kiln.

If the bottom of your kiln becomes slightly uneven, scrape off the old kiln wash and apply a new coat. Should the brick become unusually rough, it is easy to turn the bottom over for a fresh smooth surface.

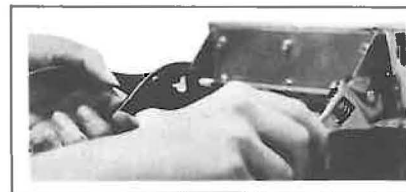

1. Remove the lid by removing acorn nuts and rod on each side of hinge, and the lock nut on lid support.

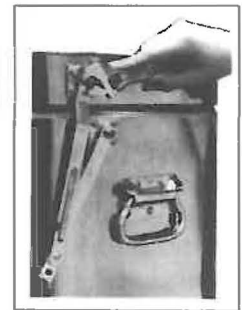

SIDEWALL MAINTENANCE

2. Carefully turn the kiln upside down on a piece of cardboard or similar padded surface, and make a mark on the steel base so it will be easy to reline the screw holes.

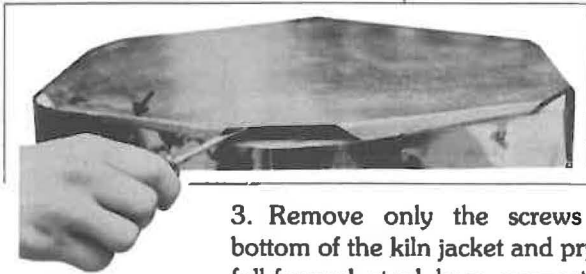
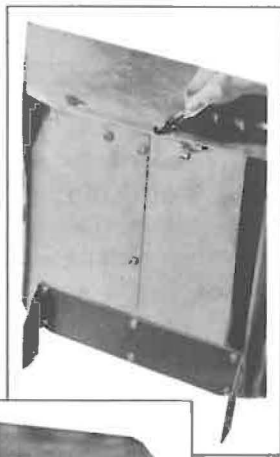

3. Remove only the screws at the bottom of the kiln jacket and pry off the full-formed steel base support with a screwdriver.



4. Take brick bottom out and turn it over. Place block insulation over the brick in large kilns.

5. Replace the steel base. If screw holes are difficult to reline, drill an extra hole in each side and tighten screws in both the old holes and the new holes. Place the kiln in upright position.



6. Replace lid by connecting hanger halves (reversing Step 1 of this section). Keep nuts and rod loose enough for hinge to have floating action when lifted.

If you have a high loss of brick in your kiln due to glaze melting and digging into the floor, it is best to replace the bottom. You may patch the bottom of your kiln, however, by thinning repair cement to the consistency of coffee cream and then mixing with coarse grog made from crushed insulating firebrick. When fired this will leave a hard durable surface. Do not use repair cement without grog for filling large holes, as it will crack and pull out, and, as it is not an insulator, will cause hot spots.

The insulating refractory brick used in the walls of your kiln is extremely fragile and if struck by your shelves or ware during loading and unloading it is likely that a chip will appear when the kiln sidewalls expand and contract during the next firing. Wall brick should be repaired immediately to prevent further damage.

SMALL CHIP REPAIR

1. If a portion of the lip of a recessed element groove is chipped, it can easily be repaired with Paragon Kiln Coating and Repair Cement.

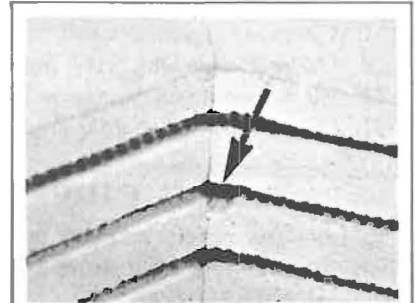

2. Build up area with repair cement and shape to groove contour using a spatula.

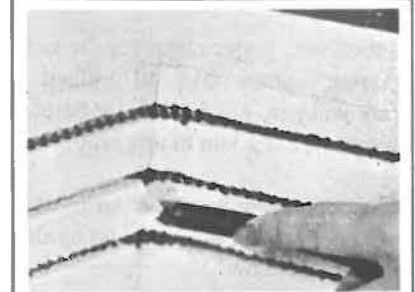

3. Remove the excess cement from the element groove and wall with a knife or screwdriver. Sand smooth after it has dried for eight hours or overnight.

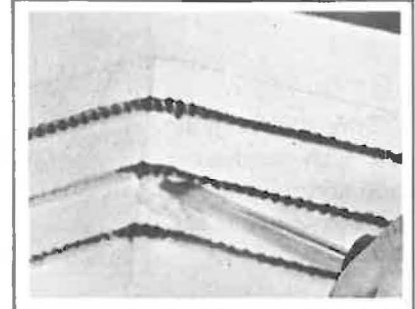

GLAZE SPOT REPAIR

Sometimes glaze will get on the walls of the kiln during firing. If not repaired at once, the glaze will remelt each time the kiln is fired and possibly spread into an element groove causing the element to burn out. Glazed spots should be repaired as soon as they are discovered by carefully digging all of the glaze out of the brick with a screwdriver or knife. Next, clean out all of the dust and fill the hole with repair kiln cement.

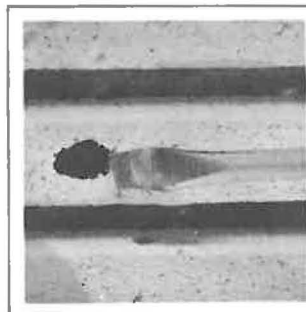

SMALL PIECE REPAIR

1. Damaged area crumbled too badly to cement back into place should be trimmed out.

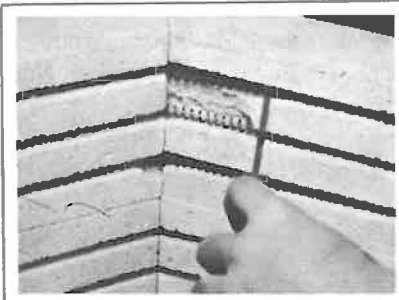

2. Cut a piece of new brick to fit the damaged area. Apply repair cement to the damaged area and the new brick.

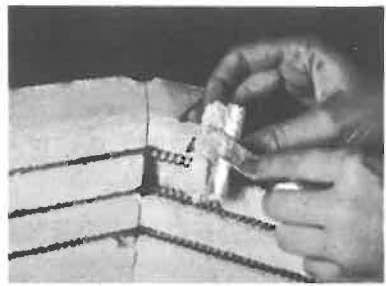

3. Work rapidly so the cement remains wet and press the brick back into place. Remove the excess cement from the element groove and the wall of your kiln. Sand smooth after it has dried.

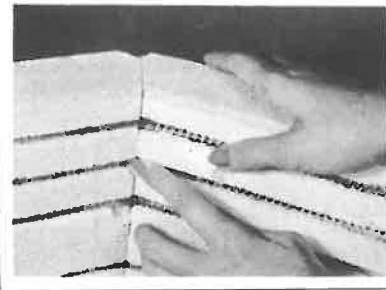

FULL WALL REPAIR

Replace a firebrick as a last resort. In most cases you can patch damaged brick with repair cement. But for those few cases when replacing brick is necessary, here's the easiest method.

1. **UNPLUG** kiln. Remove the lid by removing screws from bottom of hinge. Remove lock-in lid support. Lift the lid off the kiln.

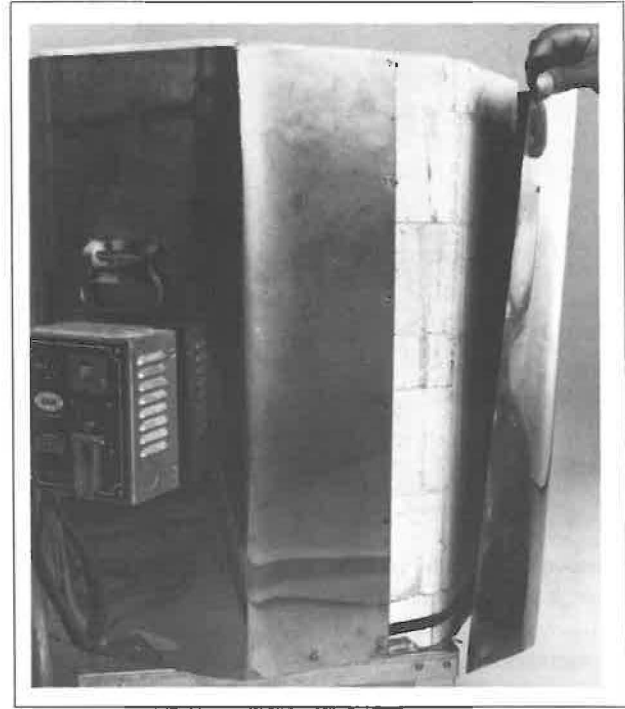
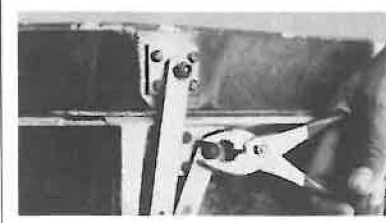
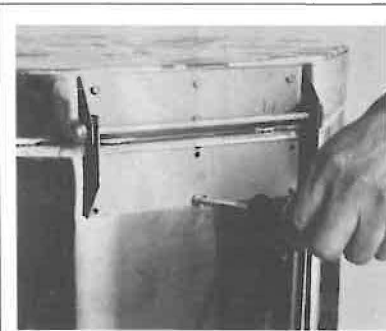

2. Remove the screws that fasten the case together. Peel back the case far enough to gain access to the brick you're replacing.

3. Gently lift element up from bottom of element grooves of the brick you're replacing. Use the tip of a pencil to lift element. The element should be above the lip of the recessed groove so that it will remain undamaged when you pull the brick out. But do not pull element out of the brick groove. The element is brittle and breaks very easily.

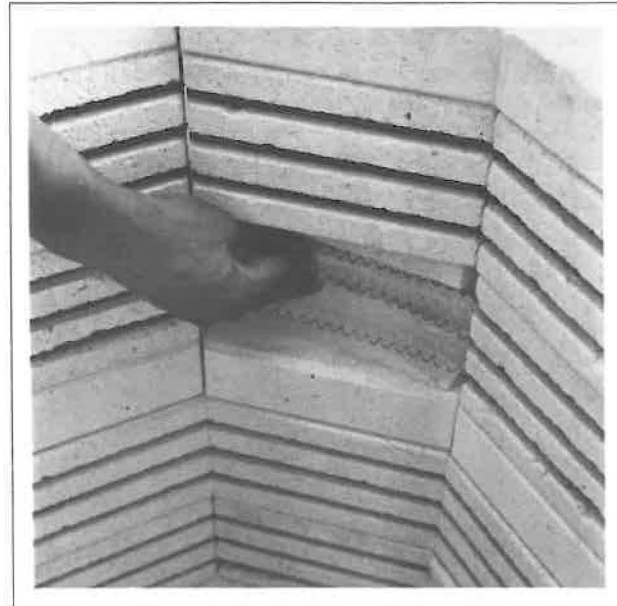

4. Reach inside firing chamber and push the damaged firebrick outward. Do not touch element.

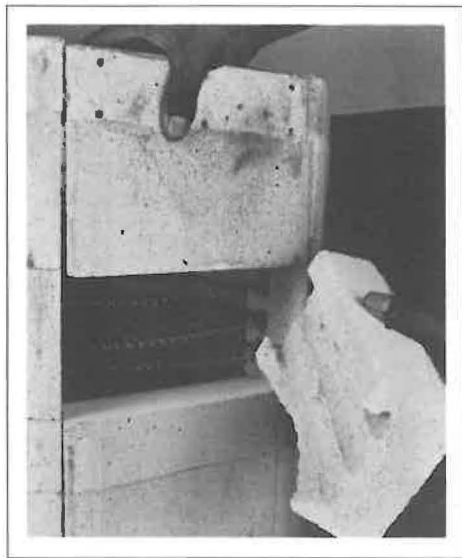

5. Remove firebrick by pulling from the outside of the firing chamber. If the firebricks above the one you're removing are loose, have someone hold them in place while you remove the damaged brick.

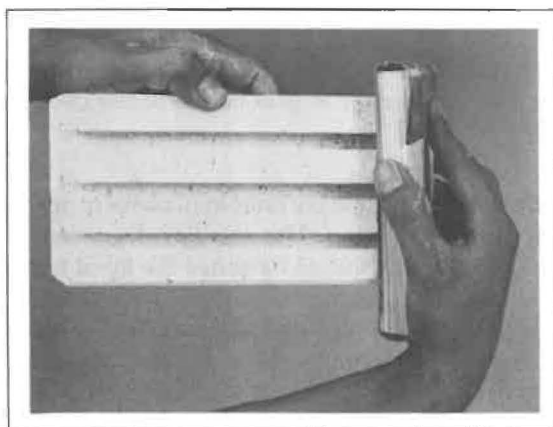

6. Insert new firebrick into place. Sand the ends if it doesn't fit. Sanding will probably be unnecessary.

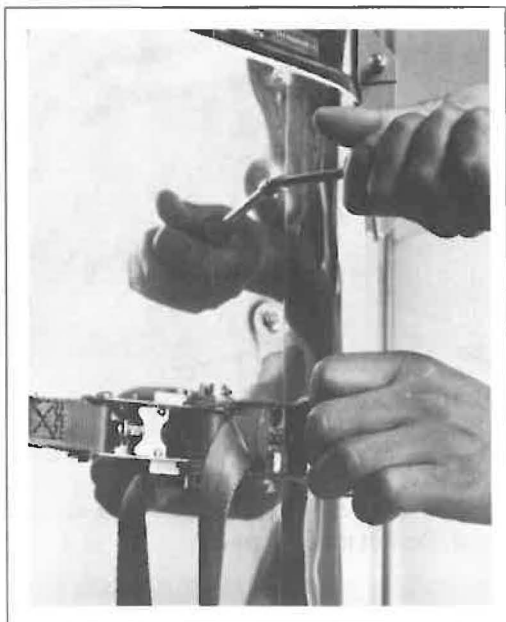

7. Reinstall the case. The easiest way to bring the case ends together is to use the Paragon case tightener. (Call your Paragon dealer to order one.) Tap the case on the flat areas all around the kiln. Use the inside of your open hand. This will help draw the case together. Reinstall case screws when the screw holes match up.

8. Reinstall lid hinge and lock-in lid support.

9. Gently lower element into the recessed grooves of the new brick. Use the pencil. The element will slide right in place almost by itself.

10. Plug in kiln and test element by turning switch on HIGH.

SWITCH REPLACEMENT ROTARY SWITCH WITH PUSH-ON TERMINALS

1. Pull off switch knob with fingertips by pulling straight out. Some switch knobs are held in place by a set screw on the side of the knob. So if knob won't come off when you pull on it, check to see if a set screw is securing it to the shaft.

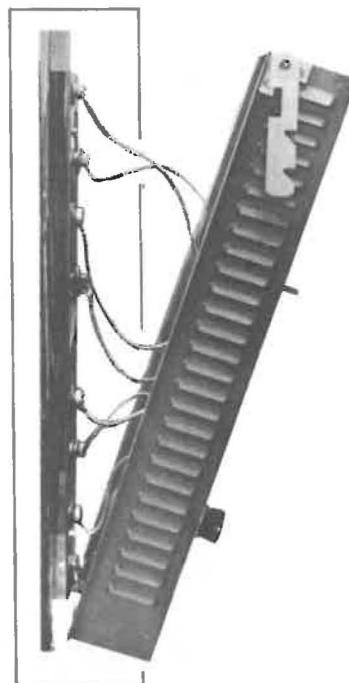

2. Remove and save the screws at the side of the switch box that hold it to the kiln, and let the switch box hang by the switch-to-element lead wires.

Before removing the switch box, always **UNPLUG** or disconnect the kiln.



3. Hold the new switch at the side of the switch box in the same position as the defective switch with the word TOP facing upward. Remove and transfer one wire at a time from the old switch to the new one making sure the connection is tight when it is pushed on.

4. Remove the single nut from the front of the switch previously under the knob. Then remove the defective switch and put the new one in its place. Install the new switch in exactly the same position as the old one, because the indicator marks on the knob cannot be read correctly if turned from its original position. After the switch is in place, put the shaft nut on, checking to make sure it is not backwards, and securely tighten so the switch will not turn during operation.

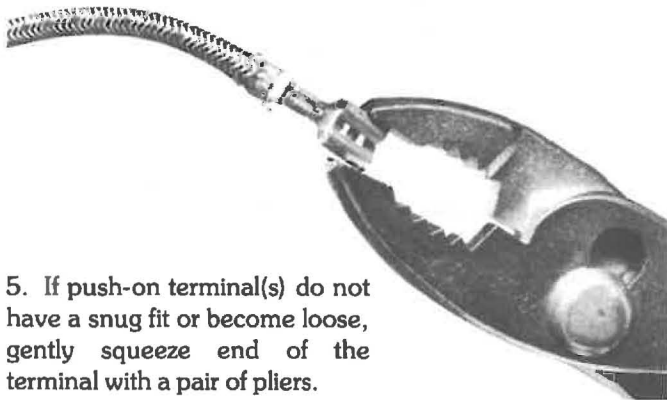

5. If push-on terminal(s) do not have a snug fit or become loose, gently squeeze end of the terminal with a pair of pliers.

6. As the switch box is moved back into place, check to see that no wires are touching each other or the element connections. Firmly fasten the switch box to the kiln using the screws removed in Step 2.

7. Line up the flat side of the switch shaft with the flat side of the switch knob shaft hole and push knob back in place. Turn the knob to make sure it is working correctly.

ROTARY SWITCH WITH SCREW-ON TERMINALS

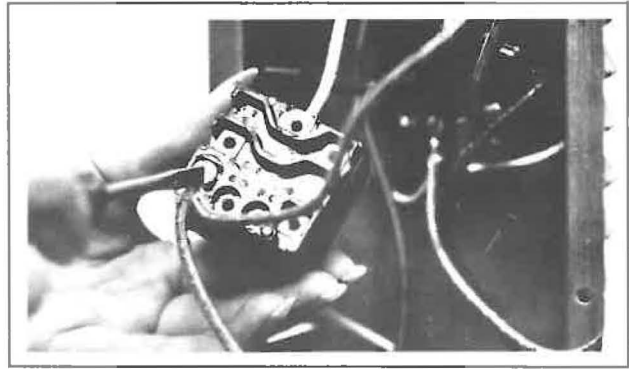

For switches with screw-on terminals, the procedure is the same, except the lead wires are screwed-on instead of being pushed-on. Remove one screw at a time from the old switch and transfer all wires under each screw to the same position on the new switch. Polish each element lead wire eyelet to a bright brassy color with sandpaper before moving it to the new switch. Tighten each screw on the new switch securely before removing the next screw on the old switch. When all wires have been transferred to the new switch, go over each screw again to be sure that it is tight.

STEPLESS CONTROL SWITCH

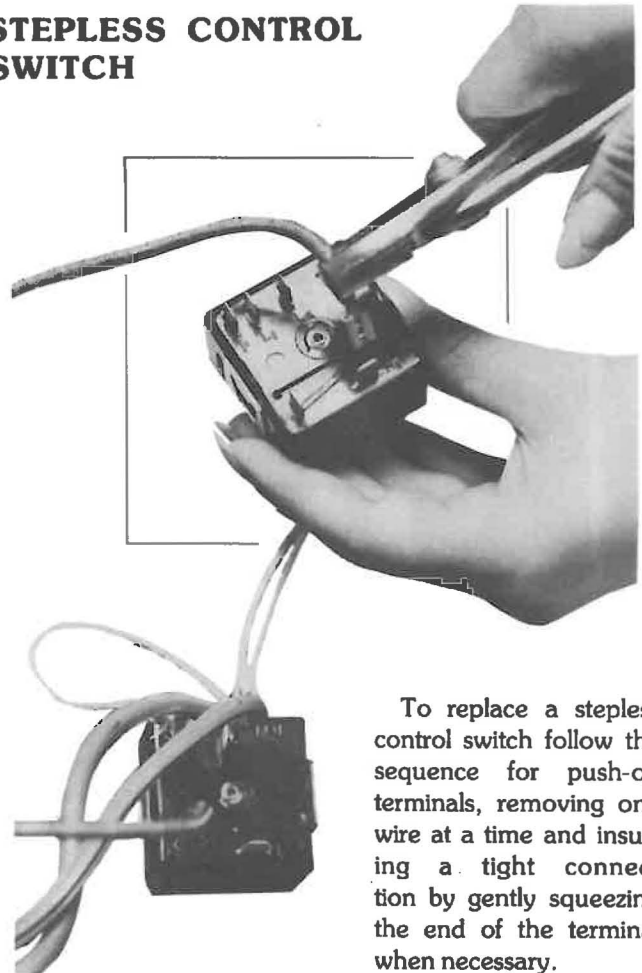

To replace a stepless control switch follow the sequence for push-on terminals, removing one wire at a time and insuring a tight connection by gently squeezing the end of the terminal when necessary.

SWITCH EQUIVALENT CHARTS

4-WAY ROTARY SWITCH EQUIVALENT CHART

Wiring diagrams designed for kilns equipped with 4-way rotary TAAP or TAAO switch (screw-on type connections) may be used with kilns of the same model equipped with a 4-way rotary switch (push-on type connections). Poles labeled with a number on one switch are equivalent to the pole labeled with the same number on the other switch and wires may thus be connected by using the number to identify which is the proper pole.

4-WAY ROTARY A-21 SWITCH (push-on type connections)



4-WAY ROTARY TAAP OR TAAO SWITCH (screw-on type connections)

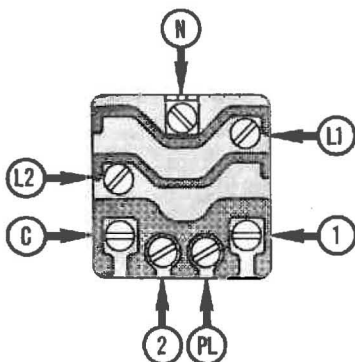

3-WAY ROTARY AND 3-WAY TOGGLE SWITCH EQUIVALENT CHART

Wiring diagrams designed for kilns equipped with 3-way rotary switches may be used with kilns of the same model equipped with 3-way toggle switches, and vice-versa, by using this chart. Poles labeled with a number on one switch are equivalent to the pole labeled with the same number on the other switch, and wires may thus be connected by using the number to identify which is the proper pole.

3-WAY ROTARY SWITCH

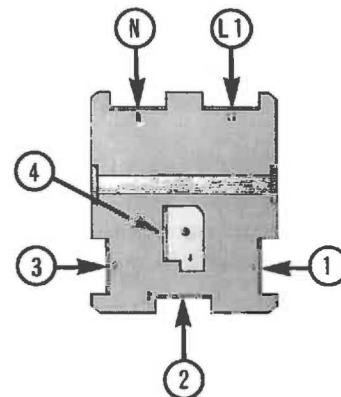

3-WAY TOGGLE SWITCH

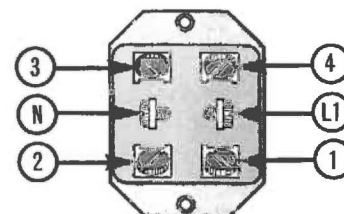

3-way toggle switches rarely become defective, because of their solid silver contact points. However, if the switch has not been used for a long period of time, tarnish will accumulate on the contact points. Tarnish may be easily removed by simply flipping the switch from on to off approximately 20 to 30 times.

PARAGON KILN LIMITED WARRANTY

Paragon kilns with a temperature rating up to and including 2300° F. are warranted to the original purchaser, subject to the listed exclusions below, to be free of defects in workmanship for a period of two years from date of original purchase from an authorized Paragon distributor or dealer. Kilns with a temperature rating of 2350° F. or higher (cone 10) are subject to the same exclusions and warranted to the original purchaser for a period of one year from original purchase date.

This warranty excludes: 1) Kilns damaged by overfiring (exceeding the melting temperature of the material being fired) regardless of cause of overfiring; 2) Ware or kiln furniture damaged by overfire; 3) Kilns allowed to exceed the maximum temperature shown on kiln's nameplate; 4) Kilns subjected to abuse, neglect, freight damage or improper storage; 5) Kilns used for either reduction or salt firing; 6) Kilns damaged by improper electrical installation; 7) Kilns used for purposes other than firing ceramic materials; 8) The patented Dawson kiln-sitter and/or limit timer manufactured by W. P. Dawson, Inc., 399 Thor Place, Brea, California 92621.

Paragon Industries will repair or replace any parts which become defective under normal and proper use during the specified period for either type kiln, providing the kiln has not been subjected to misuse or the listed exclusions. Paragon will furnish and install replacement parts at the factory with transportation costs paid by the owner; or upon receipt of defective parts at the factory, and after factory examination of the defect, replacements complete with installation instructions will be shipped postpaid to owner.

Any claim for adjustment under this warranty must include name and address of dealer from whom kiln was originally purchased. Repair or replacement of any defective parts shall fulfill all obligations of Paragon Industries. No other obligations or liabilities are assumed in connection with Paragon kilns nor does Paragon Industries authorize its distributors or dealers to assume any other obligations or liabilities.

THIS WARRANTY GIVES YOU SPECIFIC LEGAL RIGHTS,
AND YOU MAY ALSO HAVE OTHER RIGHTS
WHICH VARY FROM STATE TO STATE.



Paragon

INDUSTRIES, INC.

2011 South Town East Blvd.
Mesquite, Texas 75149-1122
972-288-7557
Fax: 972-222-0646

PARAGON KILNS

A and B series
instruction
and
service
manual

